

RCSUF

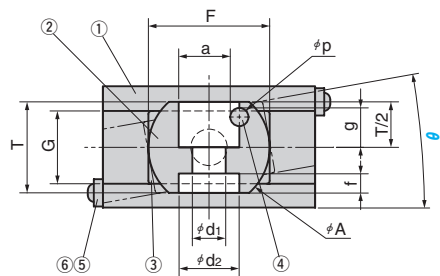
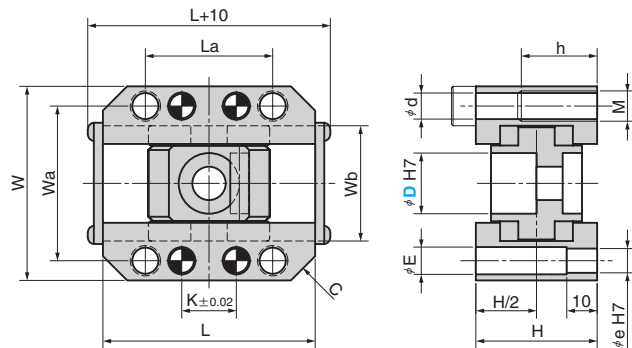
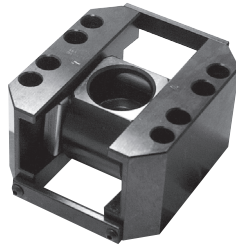

*Remove ⑤ Lock Plate as required for operation.

Table of Components

No.	Description	Qty	Material and Remark
①	Guide Rail	2	S45C (I C45 A 1045)
②	Inclined Pin Holder	1	S45C (I C45 A 1045)
③	Slide Plate	2	Bronze with Graphite
④	Loosening Lock	1	SK5M
⑤	Lock Plate	2	SS400 (A A36-89b, A283-88)
⑥	Round Head Screw	4	SCM435 (I 34CrMo4 A 4140)

D	W	Wa	L	K	La	Wb	C	d	M	h	e	E	H
10	45	36	50	16	30	26	3	3.5	M 5	14	5	6	28
12	51	40	60	20	40	29	4	6.6	M 8	20	6	6.6	35
16	54	44	65	18	38	33	8	6.6	M 8	20	6	6.6	35
20	64	51	70	18	42	38	8	8.6	M10	25	8	9	40
25	70	58	80	20	45	45	10	8.6	M10	25	8	9	44
30	78	64	100	40	70	51	8	8.6	M10	25	8	9	54
35	92	75	115	50	85	58	8	10.6	M12	30	10	11	60
40	100	82	125	50	85	66	8	10.6	M12	30	10	11	65

H Dimension (11° ≤ θ ≤ 20°)

D	T	G	F	A	p	a	g	d1	d2	f	D	11°~15°	16°~20°
10	16	17	28	20	3	8.5	6.5	6	10	3	10	—	—
12	20	20	36	25	4	10	8	7	12	5	12	—	—
16	24	20	40	30	6	13	10	9	16	6	16	41	48
20	30	24	40	40	6	17	13	11	20	7	20	47	55
25	35	26	45	45	6	22	14	14	25	9.5	25	52	61
30	38	30	55	50	6	27	15	14	25	9	30	62	72
35	40	34	70	55	8	31	15	14	25	10	35	70	82
40	43	38	70	60	8	36	16	18	32	11.5	40	78	90

Catalog No.	D	θ Increments of 1°
RCSUF	10	0°~5°
	12	
	16	
	20	0°~20°
	25	
	30	
	35	
	40	



Order

Catalog No.	D	—	θ
RCSUF	30	—	12



Option

Option Code	Specification
G	Play of 0.1 to 0.2 is provided in the width direction (Wb).



Play of 0.1 to 0.2 is provided when the tolerance between dowel holes is ± 0. For details, refer to page. 74.



Order

RCSUF 30-12-G