

KOCUF

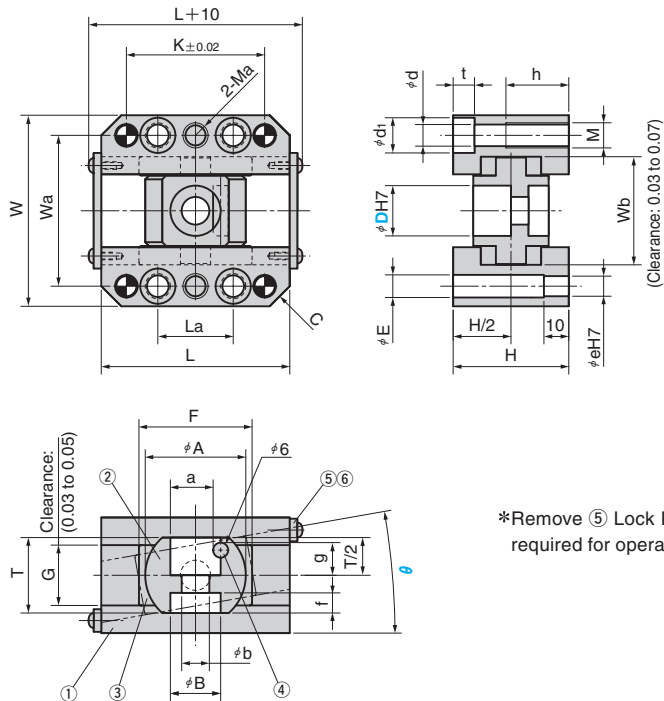

Table of Components

No.	Description	Qty	Material and Remark
①	Guide Rail	2	S45C (I) C45 (A) 1045)
②	Inclined Pin Holder	1	S45C (I) C45 (A) 1045)
③	Slide Plate	2	Bronze with Graphite
④	Loosening Lock	1	SK5M
⑤	Lock Plate	2	SS400 (A) A36-89b, 283-88)
⑥	Round Head Screw	4	SCM435 (II) 34CrMo4 (A) 4137)

D	W	Wa	L	La	K	Ma	C	H	e	E	d	d1	t	h	M	Wb
8	41	33	44	12	25	M4	3	24	4	5	3.4	6	3.4	10	M4	24
10	47	38	50	16	30	M5	3	28	5	5.5	4.5	8	5	15	M5	28
12	53	42	60	20	40	M8	4	36	6	7	6.6	11	4.8	20	M8	31
16	64	50	70	25	50	M8	6	40	6	6.6	6.6	11	6.5	20	M8	36
20	76	60	75	30	55	M10	8	46	8	9	8.6	14	8.5	25	M10	43
25	81	65	85	40	65	M10	8	48	8	9	8.6	14	8.5	25	M10	48
30	88	72	100	50	80	M10	8	54	8	9	8.6	14	8.5	25	M10	55
35	100	80	115	50	85	M12	8	60	10	11	11	18	6.5	30	M12	64
40	108	88	125	50	85	M12	8	65	10	11	11	18	7	30	M12	72

D	A	a	B	b	g	F	f	G	T
8	20	7.5	10	5	6.5	25	5	13	16
10	20	8.5	12	6	6.5	32	4	17	16
12	25	10	13	7	8.5	40	5	20	20
16	30	13	16	9	10	45	6	24	24
20	40	17	20	11	13	45	8	24	30
25	45	22	25	14	14	50	9.5	26	35
30	50	27	25	14	15	60	9	30	38
35	55	31	25	14	15	70	10	34	40
40	60	36	32	18	16	80	11.5	38	43

Catalog No.	D	θ Increments of 1°
	8	
	10	
	12	
	16	
KOCUF	20	0°~10°
	25	
	30	
	35	
	40	



Order

Catalog No.	D	θ
KOCUF	25	2



Option

Option Code	Specification
G	Play of 0.1 to 0.2 is provided in the width direction (Wb).



Play of 0.1 to 0.2 is provided when the tolerance between dowel holes is ± 0. For details, refer to page. 74.



Order KOCUF 25-2-G