

KOCU-K

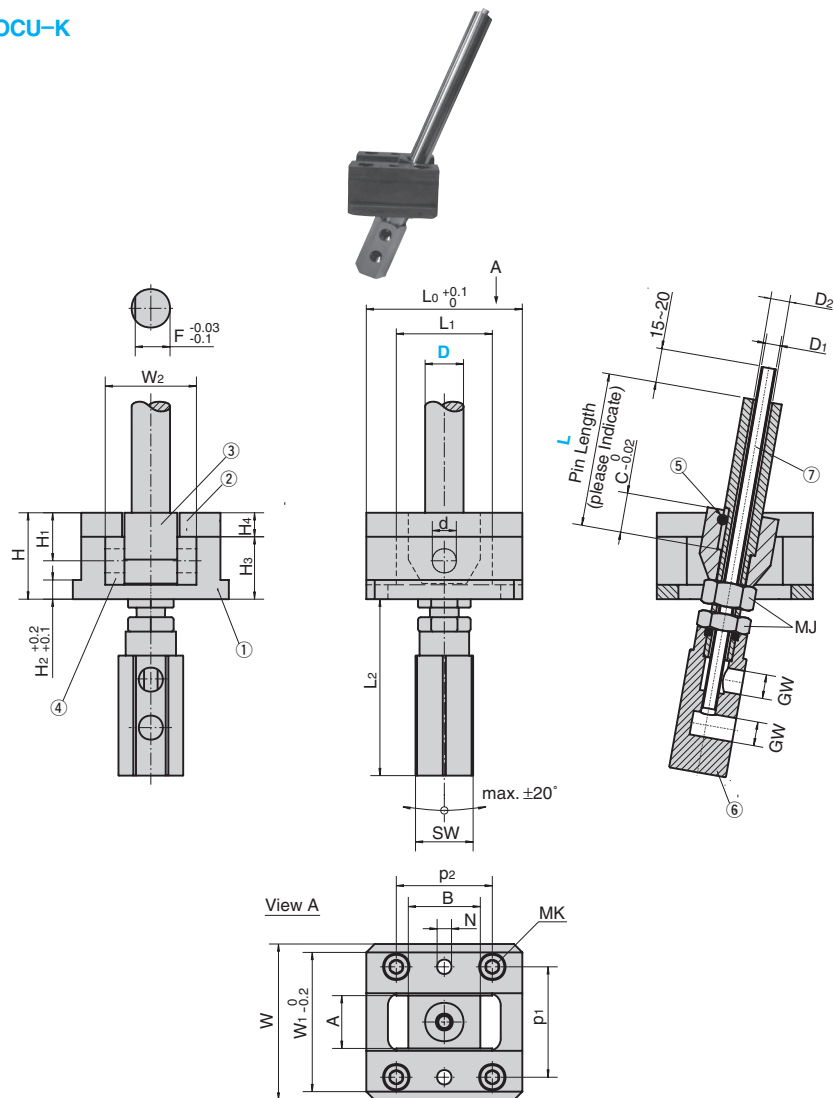

Table of Components

| No. | Description | Qty | Material and Remark | No. | Description    | Qty | Material and Remark            |
|-----|-------------|-----|---------------------|-----|----------------|-----|--------------------------------|
| ①   | Slide Base  | 1   | S45C Tufftrided     | ④   | Slide Plate    | 2   | Bronze with Graphite(SO#50SP2) |
| ②   | Upper Plate | 2   | S45C Tufftrided     | ⑤   | Loosening Lock | 1   | SK5M                           |
| ③   | Pin Holder  | 1   | S45C Tufftrided     | ⑥   | Manifold       | 1   | DIN CuZu25Al5                  |
|     |             |     |                     | ⑦   | Pipe           | 1   | Stainless Steel                |

Material detail

S45C(①~③) ... C45 A 1045

| D  | D1 | D2 | d  | A  | B  | C  | F    | H  | H1 | H2 | H3 | H4 | L0  | L1 | L2  | W   | W1  | W2 |
|----|----|----|----|----|----|----|------|----|----|----|----|----|-----|----|-----|-----|-----|----|
| 12 | 4  | 7  | 10 | 17 | 25 | 12 | 11   | 32 | 18 | 7  | 16 | 10 | 50  | 30 | 63  | 57  | 51  | 31 |
| 16 | 6  | 7  | 12 | 22 | 30 | 16 | 14.5 | 36 | 20 | 8  | 20 | 10 | 65  | 40 | 74  | 65  | 58  | 38 |
| 20 | 6  | 8  | 14 | 26 | 40 | 20 | 18   | 42 | 23 | 11 | 22 | 12 | 80  | 50 | 74  | 80  | 72  | 44 |
| 25 | 6  | 9  | 16 | 32 | 45 | 25 | 22.5 | 50 | 28 | 15 | 26 | 15 | 90  | 55 | 78  | 93  | 85  | 52 |
| 30 | 6  | 9  | 18 | 38 | 50 | 30 | 27   | 55 | 30 | 15 | 30 | 15 | 100 | 60 | 83  | 101 | 93  | 60 |
| 35 | 10 | 16 | 20 | 45 | 60 | 35 | 32   | 62 | 35 | 15 | 34 | 18 | 120 | 75 | 116 | 120 | 110 | 70 |
| 40 | 10 | 16 | 25 | 55 | 70 | 40 | 36   | 70 | 40 | 15 | 44 | 18 | 135 | 85 | 116 | 130 | 120 | 80 |
| 45 | 10 | 16 | 30 | 60 | 80 | 45 | 40   | 80 | 45 | 15 | 50 | 20 | 150 | 95 | 116 | 140 | 130 | 90 |

| p1  | p2  | MK  | N  | Travel | GW      | MJ      | SW | Catalog No. | D  | L (Max. pin length) |
|-----|-----|-----|----|--------|---------|---------|----|-------------|----|---------------------|
| 39  | 35  | M6  | 6  | 17     |         | M10×1.0 | 19 | KOCU-K      | 12 | 450                 |
| 46  | 40  | M6  | 6  | 23     |         |         |    |             | 16 |                     |
| 56  | 55  | M8  | 8  | 28     |         |         |    |             | 20 |                     |
| 66  | 65  | M10 | 10 | 31     | M10×1.0 |         | 24 |             | 25 |                     |
| 74  | 70  | M10 | 10 | 40     |         |         |    |             | 30 |                     |
| 85  | 80  | M12 | 10 | 45     |         |         |    |             | 35 | 900                 |
| 95  | 90  | M12 | 10 | 50     |         | M24×1.5 | 46 | 40          |    |                     |
| 105 | 110 | M12 | 10 | 55     |         |         |    | 45          |    |                     |



Order **Catalog No.** - **D** - **L**  
**KOCU-K** - **35** - **900**

Pipe Diameter

| D  | D1 Outer Diameter | Inner Diameter |
|----|-------------------|----------------|
| 12 | 4                 | 3              |
| 16 | 6                 | 5              |
| 20 | 6                 | 5              |
| 25 | 6                 | 5              |
| 30 | 6                 | 5              |
| 35 | 10                | 9              |
| 40 | 10                | 9              |
| 45 | 10                | 9              |