

KOCU-S

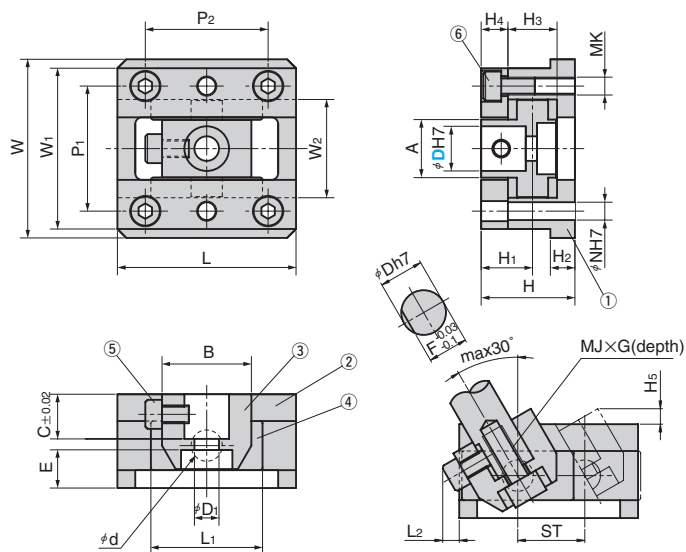
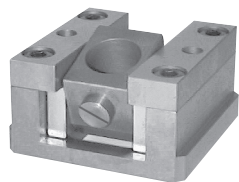

Tolerance not specified : DIN ISO 2768 - middle

Table of Components

No.	Description	Qty	Material and Remark
①	Slide Base	1	S45C Tufftrided (I C45 A 1045)
②	Upper Plate	2	S45C Tufftrided (I C45 A 1045)
③	Pin Holder	1	S45C Tufftrided (I C45 A 1045)
④	Slide Plate	2	Bronze with Graphite(SO#50 SP2)
⑤	Socket Head Screw	1	SCM435(Special) (I 34CrMo4 A 4137)
⑥	Socket Head Screw	4	SCM435(Special) (I 34CrMo4 A 4137)

D	d	D ₁	A	B	C	E	F	MJ	G	H	H ₁	H ₂	H ₃	H ₄	H ₅
8	7	4.5	11	20	8	10	7	M4	8	22	12.5	5	11	7	10.5
10	7	5.5	15	25	10	12.5	9	M5	9	27	15.5	5	15	8	11.3
12	10	7	17	25	12	15	11	M6	10	32	18	7	16	10	4
16	12	9	22	30	16	15	14.5	M8	12	36	20	8	20	10	5
20	14	11	26	40	20	16	18	M10	16	42	23	11	22	12	8
25	16	14	32	45	25	17	22.5	M12	20	50	28	15	26	15	8
30	18	14	38	50	30	17	27	M12	25	55	30	15	30	15	9
35	20	14	45	60	35	18	32	M12	30	62	35	15	34	18	10
40	25	18	55	70	40	19	36	M16	35	70	40	15	44	18	12
45	30	18	60	80	45	24	40	M16	40	80	45	15	50	20	14

D	L	L ₁	L ₂	W	W ₁	W ₂	P ₁	P ₂	MK	N	ST
8	32	20	3.6	33	30	19	24	20	M3	3	10
10	45	25	4.5	45	40	25	32	30	M4	4	18
12	50	30	5	57	51	31	39	35	M6	6	20
16	65	40	5	65	58	38	46	40	M6	6	25
20	80	50	5	80	72	44	56	55	M8	8	30
25	90	55	6	93	85	52	66	65	M10	10	35
30	100	60	7	101	93	60	74	70	M10	10	40
35	120	75	8	120	110	70	85	80	M12	10	45
40	135	85	8	130	120	80	95	90	M12	10	50
45	150	95	10	140	130	90	105	110	M12	10	55

Catalog No.	D	Order	Catalog No.	D
	8	Order	KOCU-S	20
	10			
	12			
	16			
KOCU-S	20			
	25			
	30			
	35			
	40			
	45			

Features of Unit

- Maintenance-free inclined ejector core unit for easy removing of mouldings with undercut.
- Totally self-lubricating even at temperatures up to 300± °C.
- Pivoted pin holder for maximum working angle of 30 degrees.
- Fixing by screws and dowel pins or clamping between ejector plates.