

SOSG

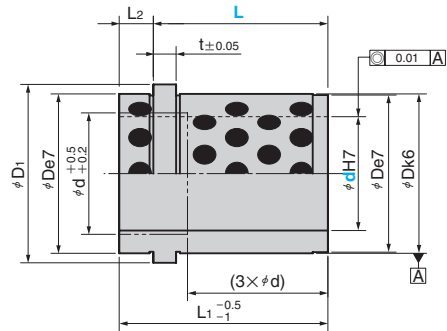

● Sliding Direction

Material : Bronze with Graphite (SO#50 SP2)

*Operation ambient temperature: 0 to 300°C



Order

SOSG **9** **017**

L1	L2	t	D	Tolerance		D1	d H7	Catalog No.	d	L
				e7	k6					
15										012
20										017
25							9		9	022
30										027
39	3	3	14	-0.032	+0.012	16	+0.015			036
15				-0.050	+0.001		0			012
20										017
25							10		SOSG	022
30										027
39										036
26										017
31										022
36	9	6	20	-0.040	+0.015	25	+0.018		14	027
45				-0.061	+0.002		0			036
55										046
65										056

L1	L2	t	D	Tolerance		D1	d H7	Catalog No.	d	L
				e7	k6					
26										017
31										022
36										027
45			20			25	15		15	036
55										046
65										056
26							+0.018			017
31							0			022
36										027
45							18		18	036
55										046
65										056
75										066
26			26			31				017
31										022
36										027
45							20		20	036
55										046
65	9	6		-0.040	+0.015			SOSG		056
75				-0.061	+0.002					066
26										017
31										022
36										027
45										036
55							22		22	046
65							+0.021			056
75							0			066
85										076
95										086
26			30			35				017
31										022
36										027
45										036
55							24		24	046
65										056
75										066
85										076
95										086

SOSG

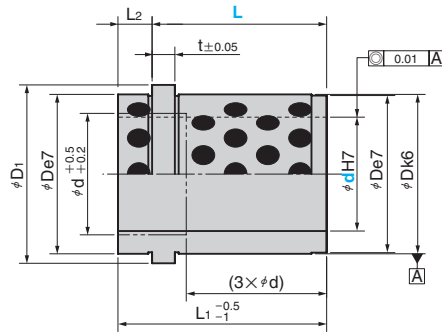

Order

Catalog No. **SOSG** d **32** - L **027**

L1	L2	t	D	Tolerance		D1	d H7	Catalog No.	d	L
				e7	k6					
36										027
45										036
55										046
65										056
75						30	$\begin{matrix} +0.021 \\ 0 \end{matrix}$		30	066
85										076
95										086
105										096
125	9	6	42	$\begin{matrix} -0.050 \\ -0.075 \end{matrix}$	$\begin{matrix} +0.018 \\ +0.002 \end{matrix}$	47			SOSG	116
36										027
45										036
55										046
65										056
75						32	$\begin{matrix} +0.021 \\ 0 \end{matrix}$		32	066
85										076
95										086
105										096
125										116

L1	L2	t	D	Tolerance		D1	d H7	Catalog No.	d	L
				e7	k6					
68										056
78										066
88										076
98							40		40	086
108										096
128										116
148										136
168	12	10	54	$\begin{matrix} -0.060 \\ -0.090 \end{matrix}$	$\begin{matrix} +0.021 \\ +0.002 \end{matrix}$	60	$\begin{matrix} +0.021 \\ +0 \end{matrix}$	SOSG		156
68										056
78										066
88										076
98							42		42	086
108										096
128										116
148										136
168										156