

- Heavy duty construction that conforms to high production runs.
- 50, 80, 150, 200 and 300 are available for the mount width.
- Available angle is 0° to 30° at increments of 5°.
- ISO springs are used.

Slide Structure and Positive Return Structure

KGSP50·80

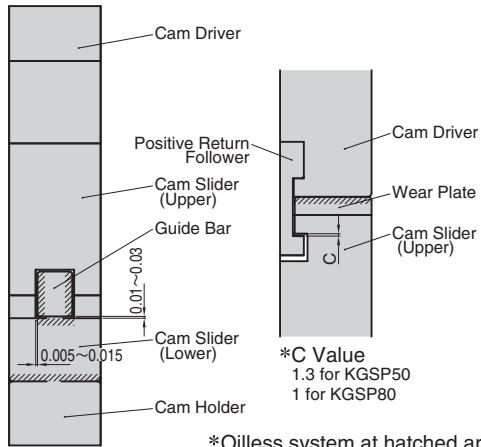

KGSP (50, 80)

- Sliding system by Guide Bar, Clearance between Cam Slider and Guide Bar is 0.005~0.015 on one side.

KGSP150~300

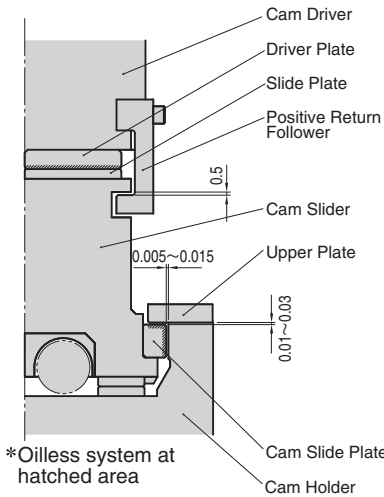

KGSP (150 or more)

- Sliding system by Box Guide, Clearance between Cam Slider and Cam Holder is 0.005~0.015 on one side.

Option of KGSP

● Metric Key Specification(-K)

KGSP50/80

LKU32-50(with 3-M8×15 bolts)

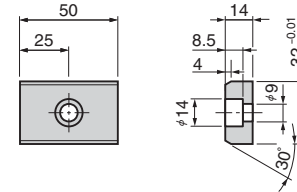

KGSP150/200

LKU32-50(with 5-M8×15 bolts)

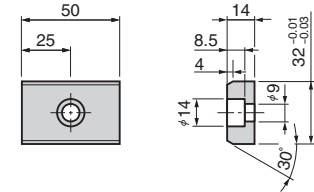

KGSP300

LKU32-50(with 7-M8×15 bolts)

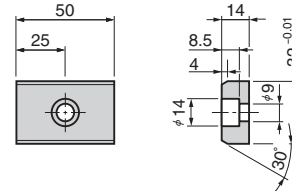

● Metric Key Specification(-KA)

KGSP50/80

LKE25-32-50(with 3-M8×15 bolts)

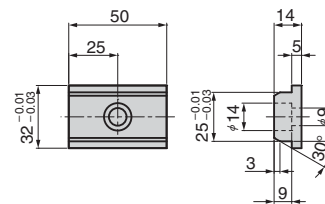

KGSP150/200

LKE25-32-50(with 5-M8×15 bolts)

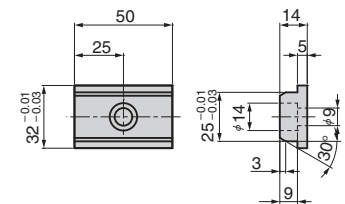

KGSP300

LKE25-32-50(with 7-M8×15 bolts)

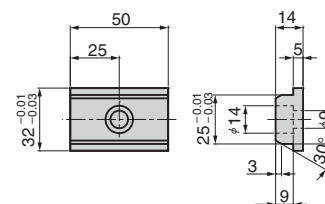

■KGSP50, 80 Structure and Assembly / Disassembly

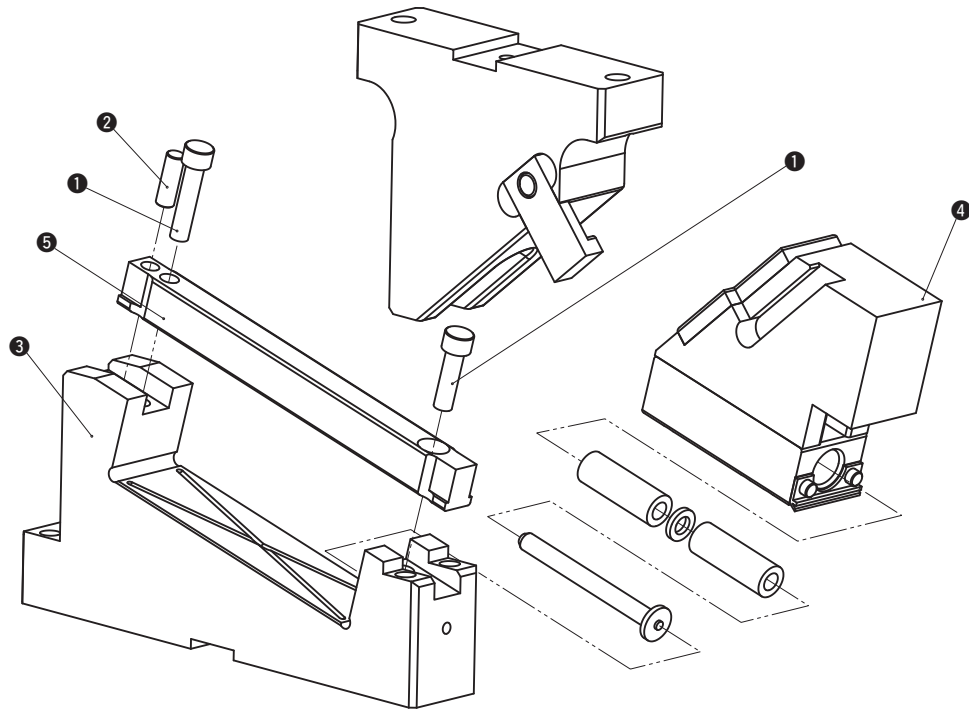

● Disassembly method of KGSP50, 80

- 1) Loosen hexagon socket head bolt (1) and remove dowel pin (2). Remove cam slider (3) and guide bar (4) from cam holder (5).
- 2) Pull and remove the guide bar from the cam slider.

● Assembly method of KGSP50, 80

- 1) Assemble components in the reverse order of disassembly.
 - Make sure that there is no foreign matter on the sliding area and assemble components.
 - The clearance between the guide bar/cam slider and the cam holder is controlled. Match the stamped serial number on the holder and slider before assembly.
 - When cam is disassembled and then reassembled, please do not forget to assemble all bolts provided.

■KGSP150, 200, 300 Structure and Assembly / Disassembly

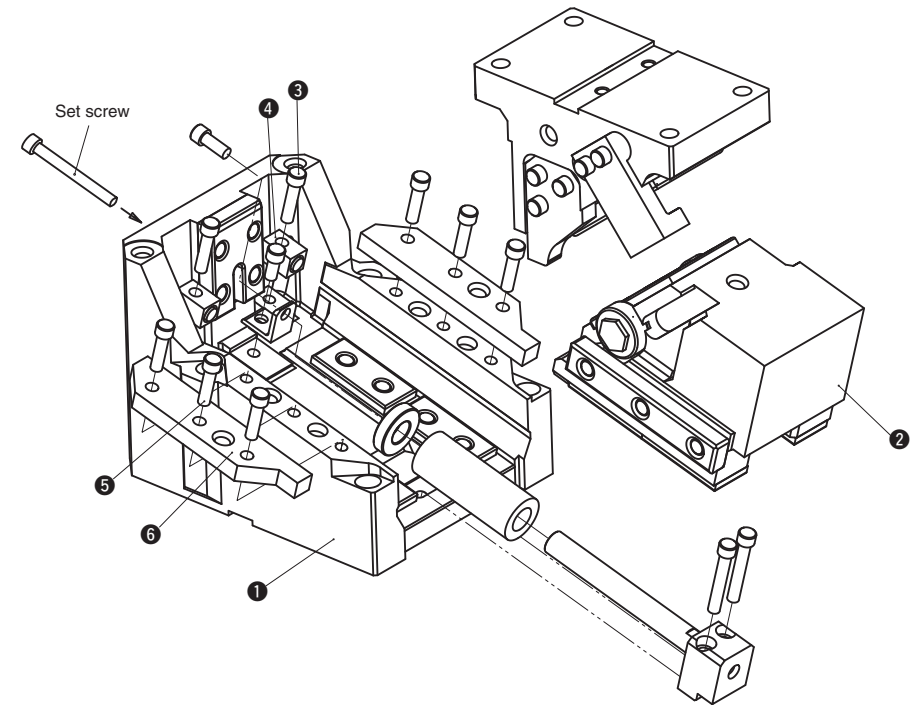

● Disassembly method of KGSP150, 200, 300

- 1) Push the slider by 20 mm or more with the set screw from the rear of cam holder (1). Loosen hexagon socket head bolt (3) and remove stopper (4) to loosen the set screw. Then, loosen hexagon socket head bolt (5) and remove upper plate (6).
- 2) Lift cam slider (2) from the cam holder.

● Assembly method of KGSP150, 200, 300

- 1) Assemble components in the reverse order of disassembly.
 - Make sure that there is no foreign matter on the sliding area and assemble components.
 - The clearance between the cam slider and the cam holder is controlled. Match the stamped serial number on the holder and slider before assembly.
 - When cam is disassembled and then reassembled, please do not forget to assemble all bolts provided.

KGSP150 - 00

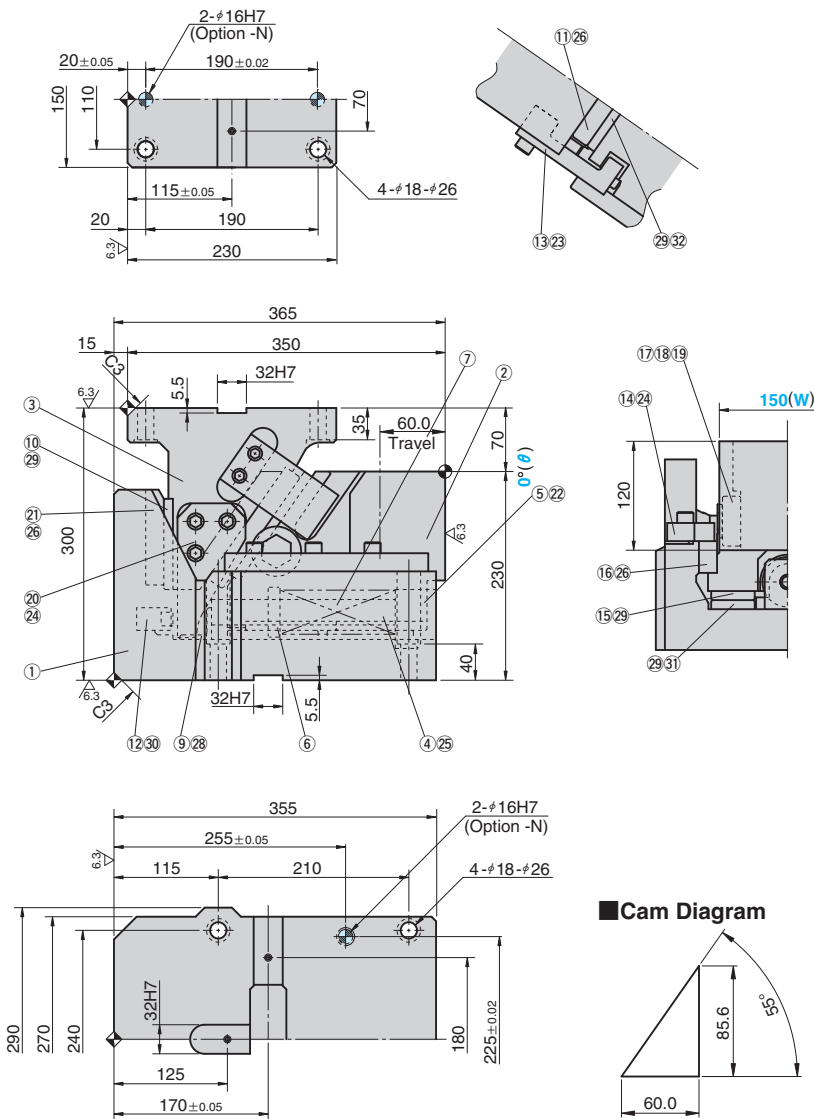

Cam Diagram

Travel S	Working Force kN(tonf)	Spring Force N(kgf)		Slider Weight kg	Total Weight kg	Catalog No.	(W)	(θ)
		Initial Load	Final Load					
60.0	117.6 (12.0)	788.8 (80.3)	3746.8 (381.5)	29.3	130.0	KGSP	150	00



Order **Catalog No.** **KGSP** **(W)** **150** **(θ)** **00**



Option Code	Specification
K	Metric dedicated key is attached for both cam holder and driver. (It is not assembled to the main unit.)
KA	Inch dedicated key is attached for both cam holder and driver. (It is not assembled to the main unit.)
N	φ16H7 dowel pin holes for the cam holder and cam driver are additionally drilled.

For detailed specification of the K and KA keys, refer to page 1666.

Refer to page 552 for detailed specifications of tapped holes and dowel pin holes (prepared hole, finish hole) for retainer.



Order **KGSP150 - 00 - KA**

Table of Components

No.	Description	Qty	Material and Remark
①	Cam Holder	1	FC250
②	Cam Slider	1	FC250
③	Cam Driver	1	FC250
④	Spring Guide Pin	1	S45C(1045)
⑤	Spring Guide Block	1	SS400(1020)
⑥	Washer	1	FC250
⑦	Coil Spring	1	TJL50-203
⑨	Bracket	1	SS400(1020)
⑩	Heel Plate	1	Bronze with Graphite(SO#50SP2)
⑪	Driver Plate	1	Bronze with Graphite(SO#50SP2)
⑫	Stopper	2	Urethane/SS400
⑬	Positive Return Follower	1	S45C(1045)
⑭	Upper Plate	2	S45C(1045)
⑮	Lower Plate	4	Bronze with Graphite(SO#50SP2)
⑯	Slide Plate	2	Bronze with Graphite(SO#50SP2)
⑰	Roller	2	S45C(1045)
⑱	Bushing	2	Bronze with Graphite(SO#50SP2)
⑲	Shaft	2	S45C(1045)
⑳	Roller Cam	2	S45C(1045)
㉑	Back Up Plate	1	S45C(1045)
㉓	Lower Slide Plate	4	S45C(1045)
㉔	Wear Plate	1	S45C(1045)

Spring Diagram

(Stripping Force at punch retraction of 5mm)

- Spring used TJL50-203(1 piece)
- Spring constant 49.3N/mm(5.02kgf/mm)

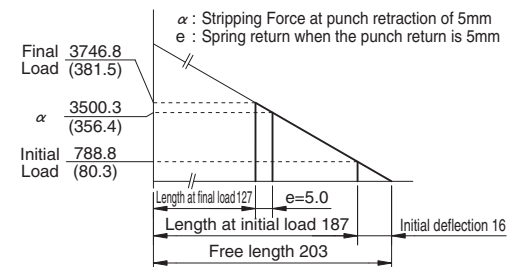

⚠ Bolts and dowel pins for assembly are not indicated. Part numbers are shown on the drawing.

KGSP150 - 05

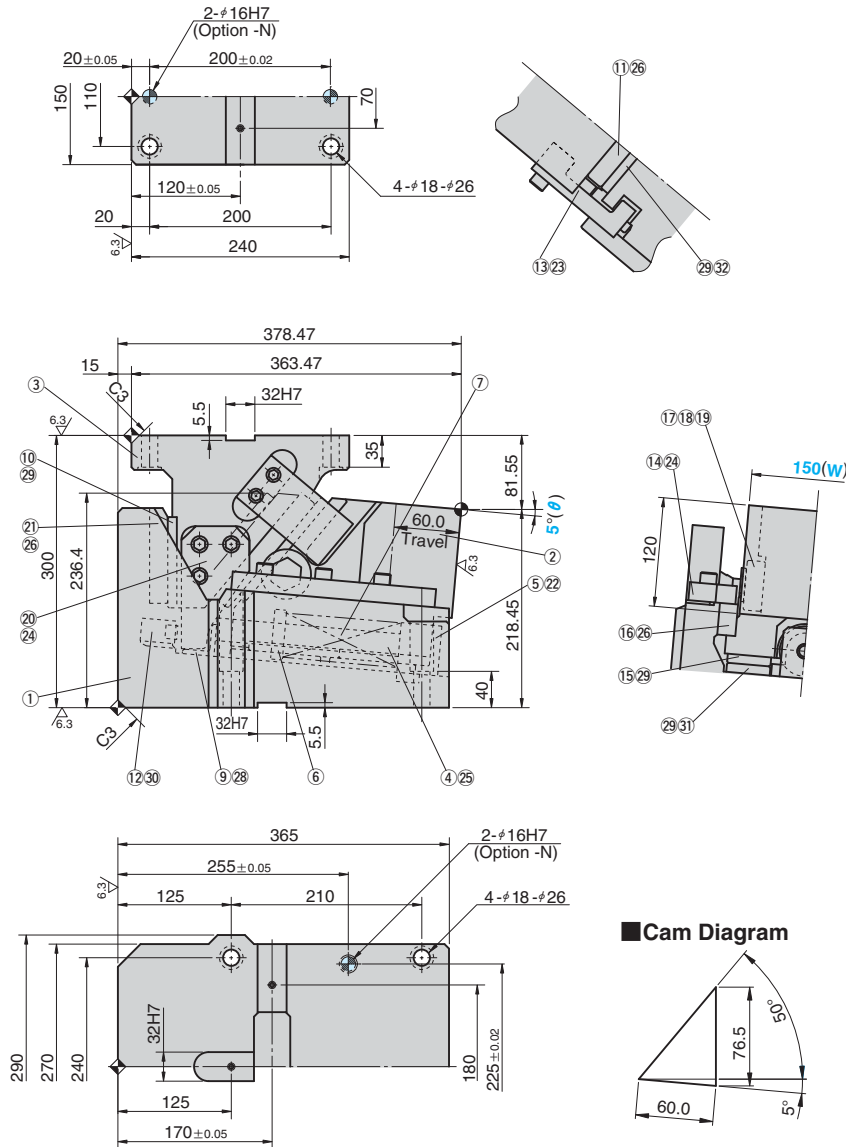

Cam Diagram

Travel S	Working Force kN(tonf)	Spring Force N(kgf)		Slider Weight kg	Total Weight kg	Catalog No.	(W)	(θ)
		Initial Load	Final Load					
60.0	117.6 (12.0)	788.8 (80.3)	3746.8 (381.5)	29.3	134.0	KGSP	150	05

Order **Catalog No.** **(W)** - **(θ)**
KGSP 150 - 05

Option	Option Code	Specification
	K	Metric dedicated key is attached for both cam holder and driver. (It is not assembled to the main unit.)
	KA	Inch dedicated key is attached for both cam holder and driver. (It is not assembled to the main unit.)
	N	φ16H7 dowel pin holes for the cam holder and cam driver are additionally drilled.

For detailed specification of the K and KA keys, refer to page 1666.

Refer to page 552 for detailed specifications of tapped holes and dowel pin holes (prepared hole, finish hole) for retainer.

Order **KGSP150 - 05 - KA**

Table of Components

No.	Description	Qty	Material and Remark
①	Cam Holder	1	FC250
②	Cam Slider	1	FC250
③	Cam Driver	1	FC250
④	Spring Guide Pin	1	S45C(1045)
⑤	Spring Guide Block	1	SS400(1020)
⑥	Washer	1	FC250
⑦	Coil Spring	1	TJL50-203
⑨	Bracket	1	SS400(1020)
⑩	Heel Plate	1	Bronze with Graphite(SO#50SP2)
⑪	Driver Plate	1	Bronze with Graphite(SO#50SP2)
⑫	Stopper	2	Urethane/SS400
⑬	Positive Return Follower	1	S45C(1045)
⑭	Upper Plate	2	S45C(1045)
⑮	Lower Plate	4	Bronze with Graphite(SO#50SP2)
⑯	Slide Plate	2	Bronze with Graphite(SO#50SP2)
⑰	Roller	2	S45C(1045)
⑱	Bushing	2	Bronze with Graphite(SO#50SP2)
⑲	Shaft	2	S45C(1045)
⑳	Roller Cam	2	S45C(1045)
㉑	Back Up Plate	1	S45C(1045)
㉓	Lower Slide Plate	4	S45C(1045)
㉔	Wear Plate	1	S45C(1045)

Spring Diagram

(Stripping Force at punch retraction of 5mm)

- Spring used TJL50-203(1 piece)
- Spring constant 49.3N/mm(5.02kgf/mm)

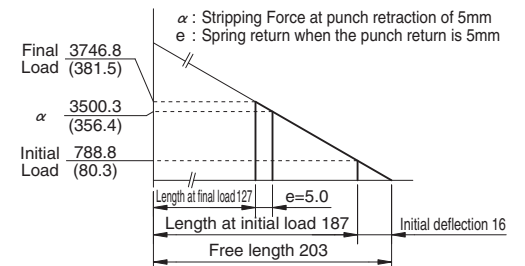

⚠ Bolts and dowel pins for assembly are not indicated. Part numbers are shown on the drawing.

KGSP150 - 10

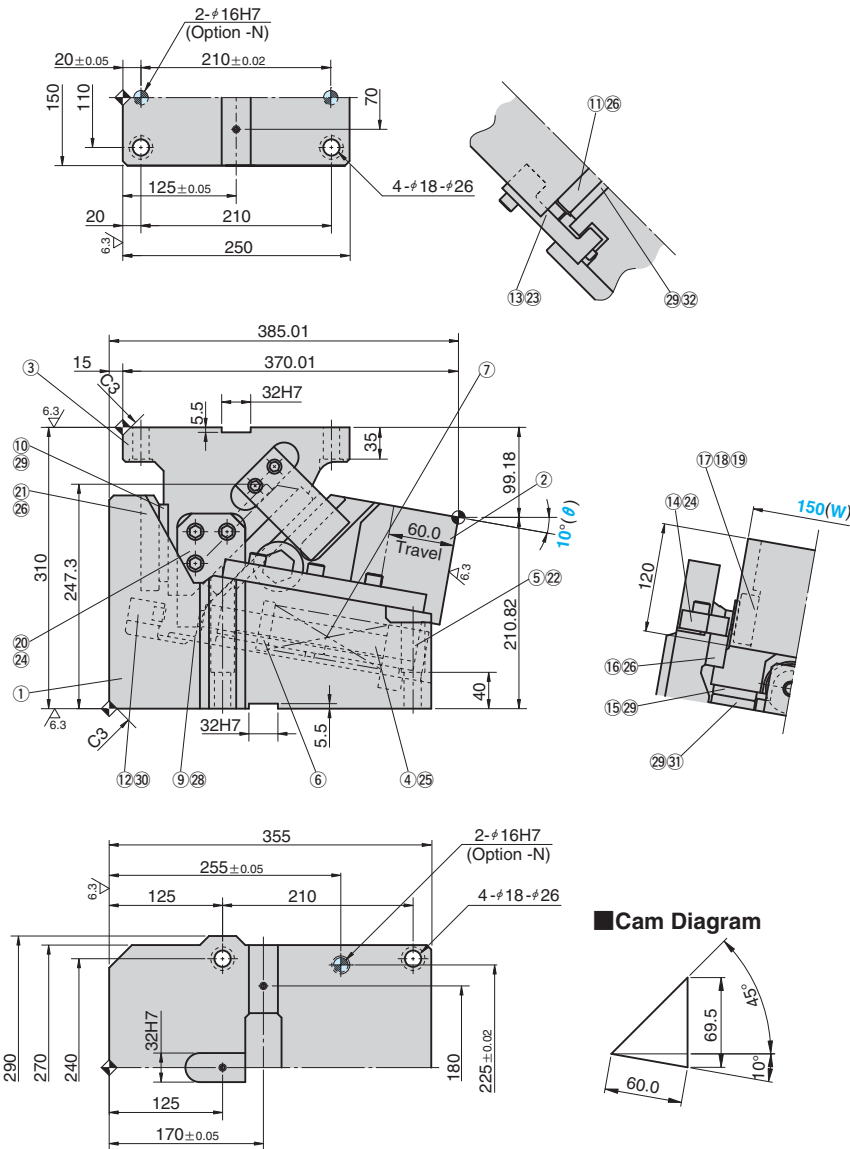

Cam Diagram

Travel S	Working Force kN(tonf)	Spring Force N(kgf)		Slider Weight kg	Total Weight kg	Catalog No.	(W)	(θ)
		Initial Load	Final Load					
60.0	117.6 (12.0)	788.8 (80.3)	3746.8 (381.5)	29.3	137.4	KGSP	150	10



Order

Catalog No. **KGSP** (W) **150** - (θ) **10**



Option

Option Code	Specification
K	Metric dedicated key is attached for both cam holder and driver. (It is not assembled to the main unit.)
KA	Inch dedicated key is attached for both cam holder and driver. (It is not assembled to the main unit.)
N	φ16H7 dowel pin holes for the cam holder and cam driver are additionally drilled.

For detailed specification of the K and KA keys, refer to page 1666.

Refer to page 552 for detailed specifications of tapped holes and dowel pin holes (prepared hole, finish hole) for retainer.



Order

KGSP150 - 10 - KA

Table of Components

No.	Description	Qty	Material and Remark
①	Cam Holder	1	FC250
②	Cam Slider	1	FC250
③	Cam Driver	1	FC250
④	Spring Guide Pin	1	S45C(1045)
⑤	Spring Guide Block	1	SS400(1020)
⑥	Washer	1	FC250
⑦	Coil Spring	1	TJL50-203
⑨	Bracket	1	SS400(1020)
⑩	Heel Plate	1	Bronze with Graphite(SO#50SP2)
⑪	Driver Plate	1	Bronze with Graphite(SO#50SP2)
⑫	Stopper	2	Urethane/SS400
⑬	Positive Return Follower	1	S45C(1045)
⑭	Upper Plate	2	S45C(1045)
⑮	Lower Plate	4	Bronze with Graphite(SO#50SP2)
⑯	Slide Plate	2	Bronze with Graphite(SO#50SP2)
⑰	Roller	2	S45C(1045)
⑱	Bushing	2	Bronze with Graphite(SO#50SP2)
⑲	Shaft	2	S45C(1045)
⑳	Roller Cam	2	S45C(1045)
㉑	Back Up Plate	1	S45C(1045)
㉓	Lower Slide Plate	4	S45C(1045)
㉔	Wear Plate	1	S45C(1045)

Spring Diagram

(Stripping Force at punch retraction of 5mm)

- Spring used TJL50-203(1 piece)
- Spring constant 49.3N/mm(5.02kgf/mm)

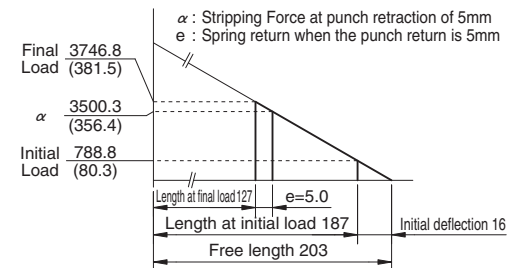

Bolts and dowel pins for assembly are not indicated. Part numbers are shown on the drawing.

KGSP150 - 15

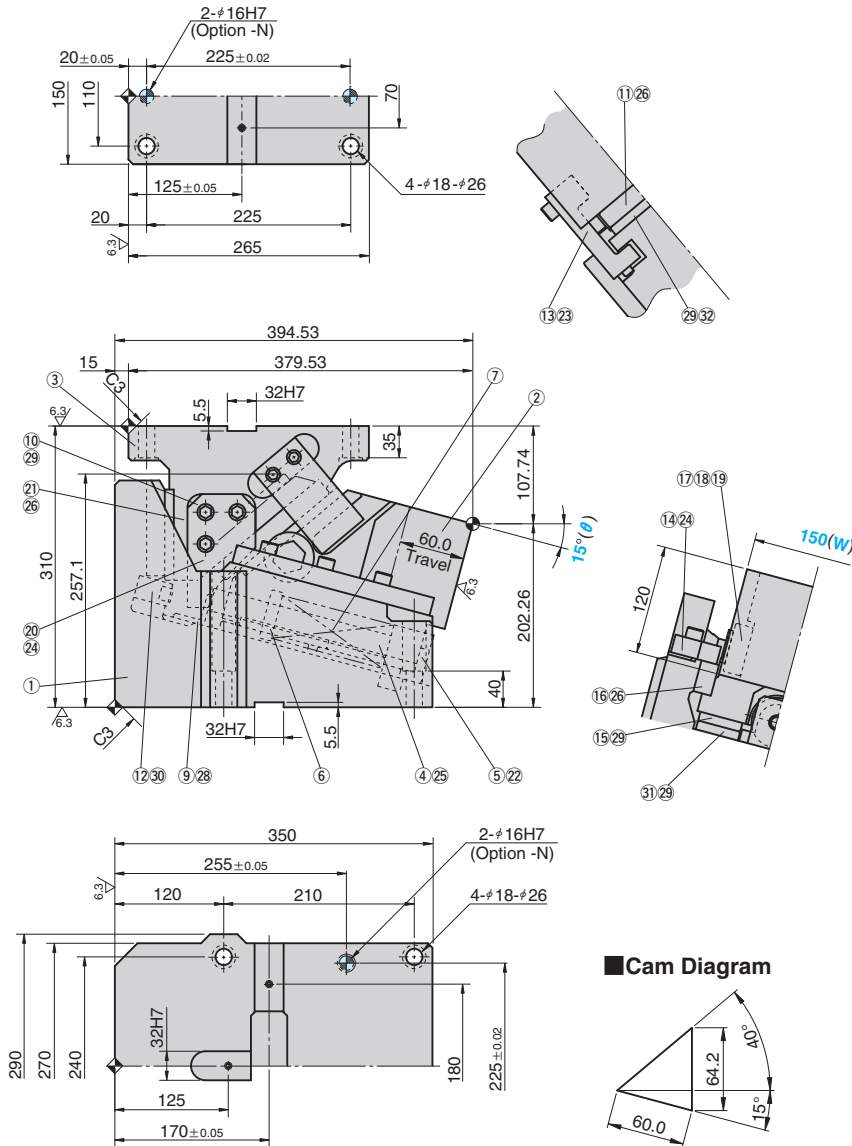

Cam Diagram

Travel S	Working Force kN(tonf)	Spring Force N(kgf)		Slider Weight kg	Total Weight kg	Catalog No.	(W)	(θ)
		Initial Load	Final Load					
60.0	117.6 (12.0)	788.8 (80.3)	3746.8 (381.5)	29.3	138.0	KGSP	150	15

Order **Catalog No.** **(W)** - **(θ)**
KGSP 150 - 15

Option	Option Code	Specification
	K	Metric dedicated key is attached for both cam holder and driver. (It is not assembled to the main unit.)
	KA	Inch dedicated key is attached for both cam holder and driver. (It is not assembled to the main unit.)
	N	φ16H7 dowel pin holes for the cam holder and cam driver are additionally drilled.

For detailed specification of the K and KA keys, refer to page 1666.

Refer to page 552 for detailed specifications of tapped holes and dowel pin holes (prepared hole, finish hole) for retainer.

Order **KGSP150 - 15 - KA**

Table of Components

No.	Description	Qty	Material and Remark
①	Cam Holder	1	FC250
②	Cam Slider	1	FC250
③	Cam Driver	1	FC250
④	Spring Guide Pin	1	S45C(1045)
⑤	Spring Guide Block	1	SS400(1020)
⑥	Washer	1	FC250
⑦	Coil Spring	1	TJL50-203
⑨	Bracket	1	SS400(1020)
⑩	Heel Plate	1	Bronze with Graphite(SO#50SP2)
⑪	Driver Plate	1	Bronze with Graphite(SO#50SP2)
⑫	Stopper	2	Urethane/SS400
⑬	Positive Return Follower	1	S45C(1045)
⑭	Upper Plate	2	S45C(1045)
⑮	Lower Plate	4	Bronze with Graphite(SO#50SP2)
⑯	Slide Plate	2	Bronze with Graphite(SO#50SP2)
⑰	Roller	2	S45C(1045)
⑱	Bushing	2	Bronze with Graphite(SO#50SP2)
⑲	Shaft	2	S45C(1045)
⑳	Roller Cam	2	S45C(1045)
㉑	Back Up Plate	1	S45C(1045)
㉓	Lower Slide Plate	4	S45C(1045)
㉔	Wear Plate	1	S45C(1045)

Spring Diagram

(Stripping Force at punch retraction of 5mm)

- Spring used TJL50-203(1 piece)
- Spring constant 49.3N/mm(5.02kgf/mm)

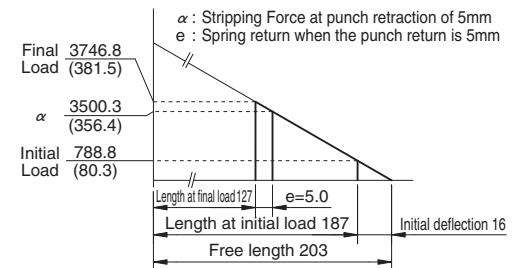

⚠ Bolts and dowel pins for assembly are not indicated. Part numbers are shown on the drawing.

KGSP150 - 20

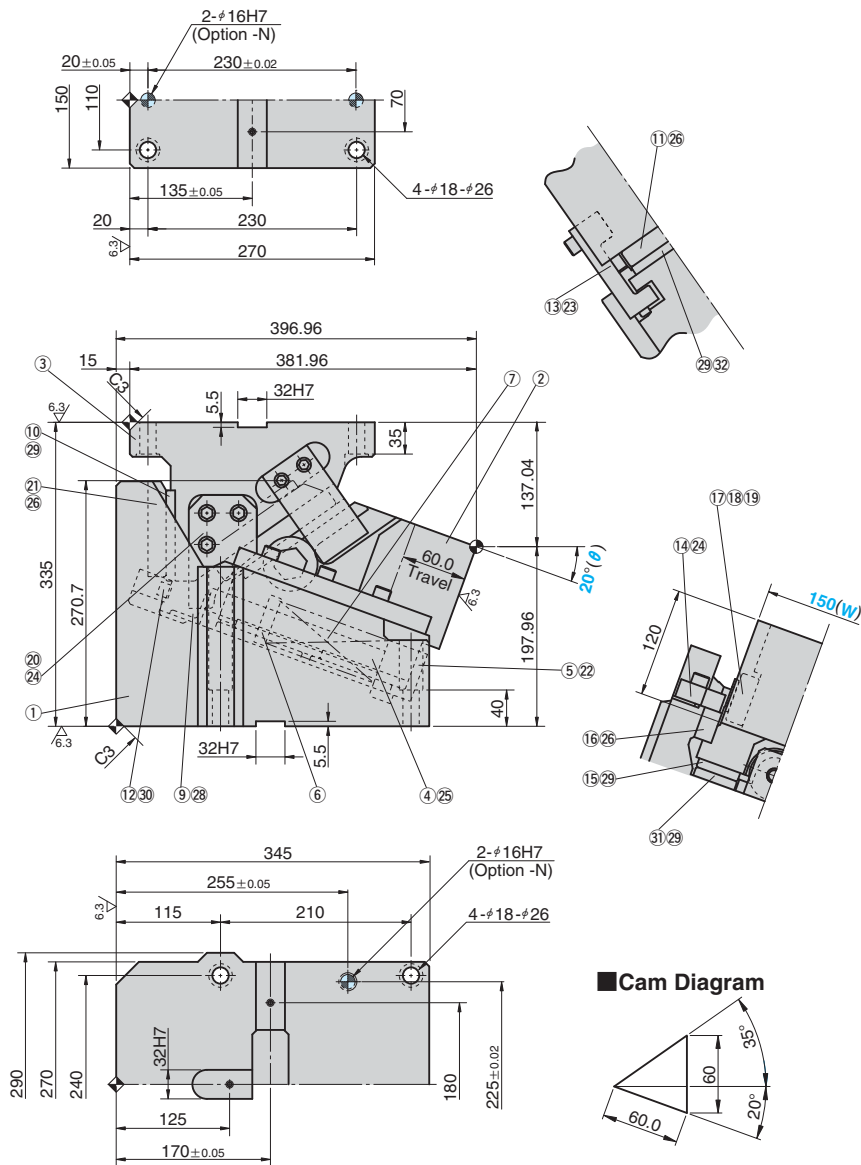

Cam Diagram

Travel S	Working Force kN(tonf)	Spring Force N(kgf)		Slider Weight kg	Total Weight kg	Catalog No.	(W)	(θ)
		Initial Load	Final Load					
60.0	117.6 (12.0)	788.8 (80.3)	3746.8 (381.5)	29.3	146.0	KGSP	150	20

Order **Catalog No.** **(W)** - **(θ)**
KGSP 150 - 20

Option Code	Specification
K	Metric dedicated key is attached for both cam holder and driver. (It is not assembled to the main unit.)
KA	Inch dedicated key is attached for both cam holder and driver. (It is not assembled to the main unit.)
N	φ16H7 dowel pin holes for the cam holder and cam driver are additionally drilled.

For detailed specification of the K and KA keys, refer to page 1666.

Refer to page 552 for detailed specifications of tapped holes and dowel pin holes (prepared hole, finish hole) for retainer.

Order **KGSP150 - 20 - KA**

Table of Components

No.	Description	Qty	Material and Remark
①	Cam Holder	1	FC250
②	Cam Slider	1	FC250
③	Cam Driver	1	FC250
④	Spring Guide Pin	1	S45C(1045)
⑤	Spring Guide Block	1	SS400(1020)
⑥	Washer	1	FC250
⑦	Coil Spring	1	TJL50-203
⑨	Bracket	1	SS400(1020)
⑩	Heel Plate	1	Bronze with Graphite(SO#50SP2)
⑪	Driver Plate	1	Bronze with Graphite(SO#50SP2)
⑫	Stopper	2	Urethane/SS400
⑬	Positive Return Follower	1	S45C(1045)
⑭	Upper Plate	2	S45C(1045)
⑮	Lower Plate	4	Bronze with Graphite(SO#50SP2)
⑯	Slide Plate	2	Bronze with Graphite(SO#50SP2)
⑰	Roller	2	S45C(1045)
⑱	Bushing	2	Bronze with Graphite(SO#50SP2)
⑲	Shaft	2	S45C(1045)
⑳	Roller Cam	2	S45C(1045)
㉑	Back Up Plate	1	S45C(1045)
㉓	Lower Slide Plate	4	S45C(1045)
㉔	Wear Plate	1	S45C(1045)

Spring Diagram

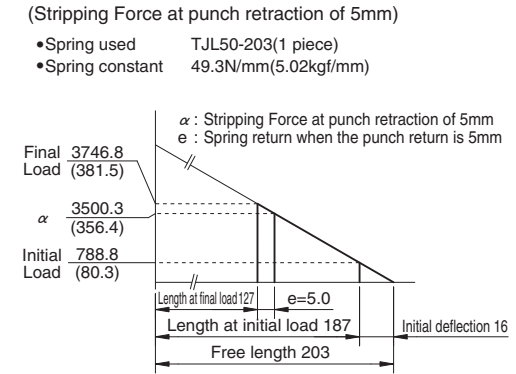

⚠ Bolts and dowel pins for assembly are not indicated. Part numbers are shown on the drawing.

KGSP150 - 25

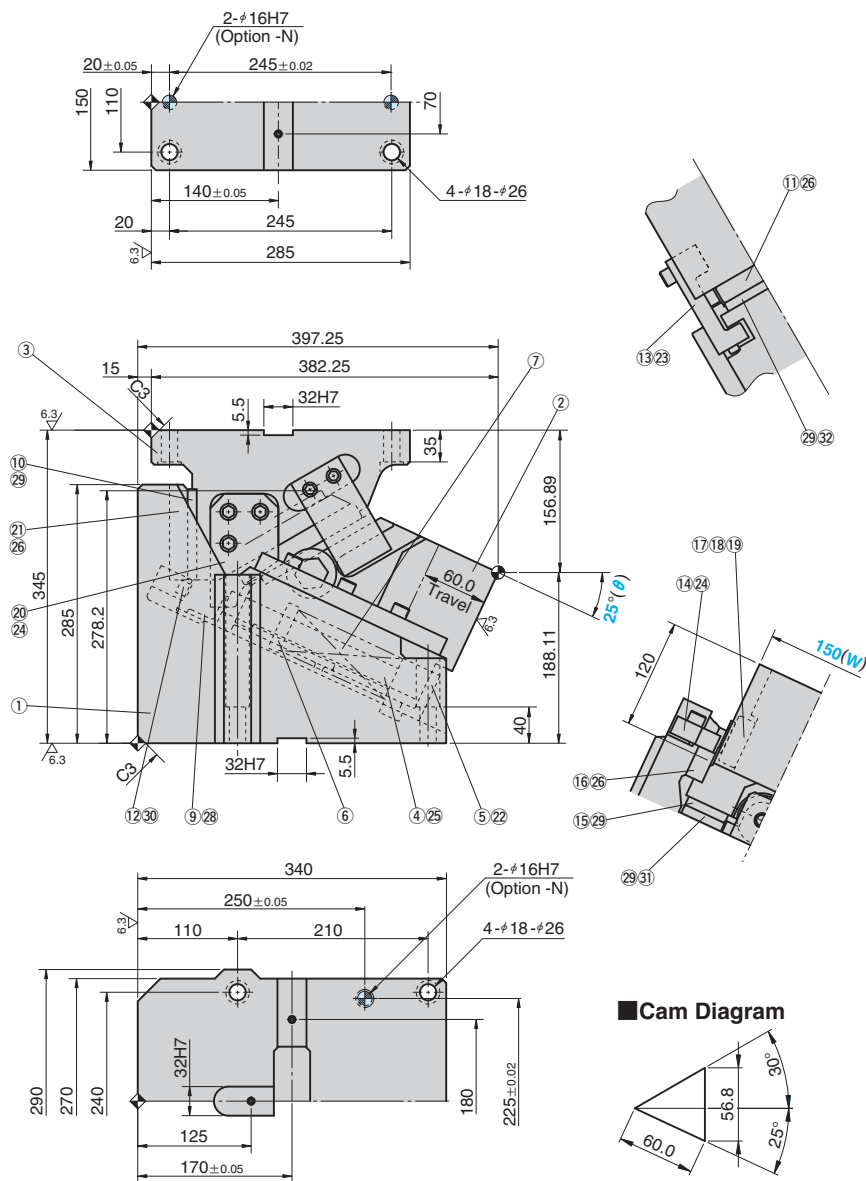

Cam Diagram

Travel S	Working Force kN(tonf)	Spring Force N(kgf)		Slider Weight kg	Total Weight kg	Catalog No.	(W)	(θ)
		Initial Load	Final Load					
60.0	117.6 (12.0)	788.8 (80.3)	3746.8 (381.5)	29.3	150.0	KGSP	150	25



Order **Catalog No.** **KGSP** **(W)** **150** **(θ)** **25**



Option Code	Specification
K	Metric dedicated key is attached for both cam holder and driver. (It is not assembled to the main unit.)
KA	Inch dedicated key is attached for both cam holder and driver. (It is not assembled to the main unit.)
N	φ16H7 dowel pin holes for the cam holder and cam driver are additionally drilled.

For detailed specification of the K and KA keys, refer to page 1666.

Refer to page 552 for detailed specifications of tapped holes and dowel pin holes (prepared hole, finish hole) for retainer.



Order **KGSP150 - 25 - KA**

Table of Components

No.	Description	Qty	Material and Remark
①	Cam Holder	1	FC250
②	Cam Slider	1	FC250
③	Cam Driver	1	FC250
④	Spring Guide Pin	1	S45C(1045)
⑤	Spring Guide Block	1	SS400(1020)
⑥	Washer	1	FC250
⑦	Coil Spring	1	TJL50-203
⑨	Bracket	1	SS400(1020)
⑩	Heel Plate	1	Bronze with Graphite(SO#50SP2)
⑪	Driver Plate	1	Bronze with Graphite(SO#50SP2)
⑫	Stopper	2	Urethane/SS400
⑬	Positive Return Follower	1	S45C(1045)
⑭	Upper Plate	2	S45C(1045)
⑮	Lower Plate	4	Bronze with Graphite(SO#50SP2)
⑯	Slide Plate	2	Bronze with Graphite(SO#50SP2)
⑰	Roller	2	S45C(1045)
⑱	Bushing	2	Bronze with Graphite(SO#50SP2)
⑳	Shaft	2	S45C(1045)
㉑	Roller Cam	2	S45C(1045)
㉒	Back Up Plate	1	S45C(1045)
㉓	Lower Slide Plate	4	S45C(1045)
㉔	Wear Plate	1	S45C(1045)

Spring Diagram

(Stripping Force at punch retraction of 5mm)

- Spring used TJL50-203(1 piece)
- Spring constant 49.3N/mm(5.02kgf/mm)

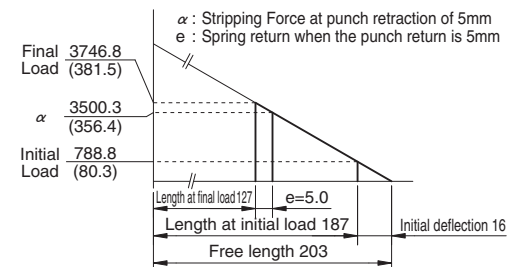

⚠ Bolts and dowel pins for assembly are not indicated. Part numbers are shown on the drawing.

KGSP150 - 30

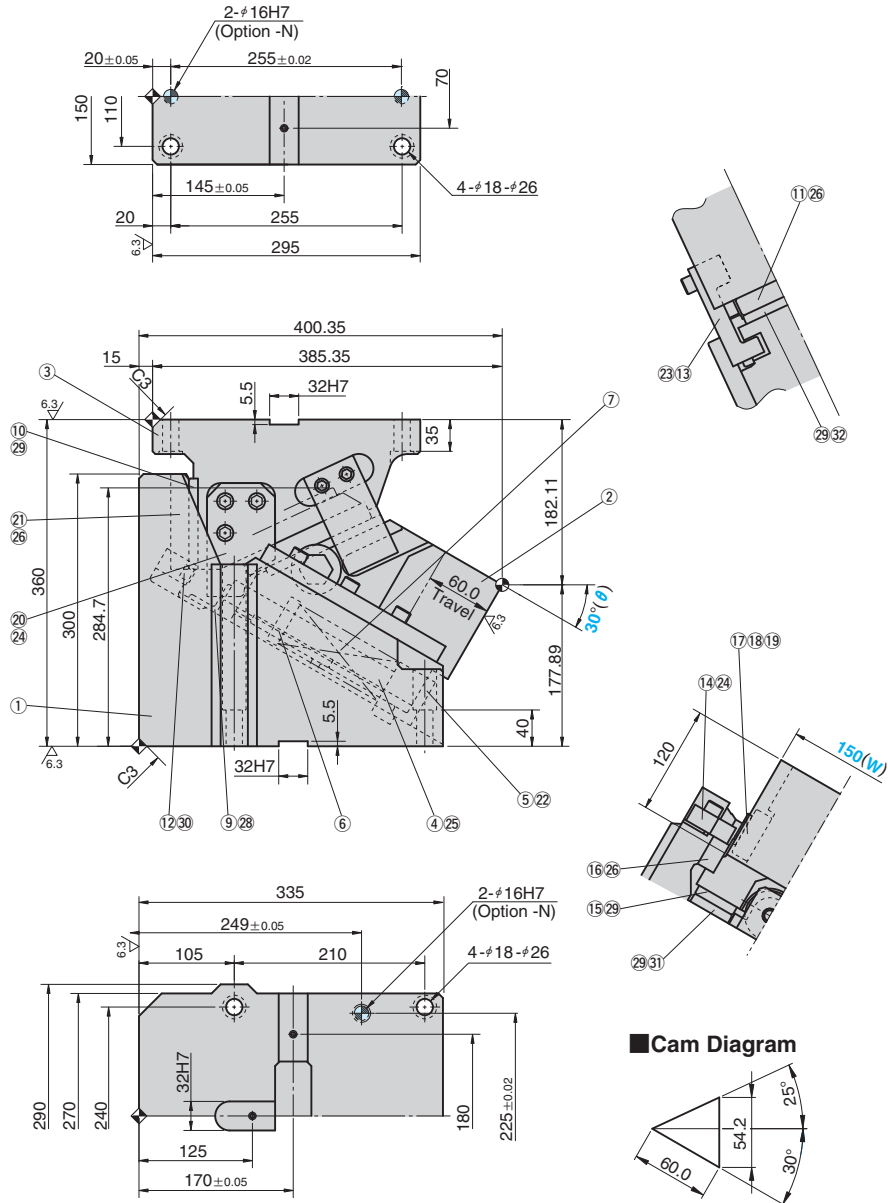

Cam Diagram

Travel S	Working Force kN(tonf)	Spring Force N(kgf)		Slider Weight kg	Total Weight kg	Catalog No.	(W)	(θ)
		Initial Load	Final Load					
60.0	117.6 (12.0)	788.8 (80.3)	3746.8 (381.5)	29.3	161.0	KGSP	150	30



Order

Catalog No. **KGSP** (W) **150** - (θ) **30**



Option

Option Code	Specification
K	Metric dedicated key is attached for both cam holder and driver. (It is not assembled to the main unit.)
KA	Inch dedicated key is attached for both cam holder and driver. (It is not assembled to the main unit.)
N	φ16H7 dowel pin holes for the cam holder and cam driver are additionally drilled.

For detailed specification of the K and KA keys, refer to page 1666.

Refer to page 552 for detailed specifications of tapped holes and dowel pin holes (prepared hole, finish hole) for retainer.



Order

KGSP150 - 30 - KA

Table of Components

No.	Description	Qty	Material and Remark
①	Cam Holder	1	FC250
②	Cam Slider	1	FC250
③	Cam Driver	1	FC250
④	Spring Guide Pin	1	S45C(1045)
⑤	Spring Guide Block	1	SS400(1020)
⑥	Washer	1	FC250
⑦	Coil Spring	1	TJL50-203
⑨	Bracket	1	SS400(1020)
⑩	Heel Plate	1	Bronze with Graphite(SO#50SP2)
⑪	Driver Plate	1	Bronze with Graphite(SO#50SP2)
⑫	Stopper	2	Urethane/SS400
⑬	Positive Return Follower	1	S45C(1045)
⑭	Upper Plate	2	S45C(1045)
⑮	Lower Plate	4	Bronze with Graphite(SO#50SP2)
⑯	Slide Plate	2	Bronze with Graphite(SO#50SP2)
⑰	Roller	2	S45C(1045)
⑱	Bushing	2	Bronze with Graphite(SO#50SP2)
⑲	Shaft	2	S45C(1045)
⑳	Roller Cam	2	S45C(1045)
㉑	Back Up Plate	1	S45C(1045)
㉓	Lower Slide Plate	4	S45C(1045)
㉔	Wear Plate	1	S45C(1045)

Spring Diagram

(Stripping Force at punch retraction of 5mm)

- Spring used TJL50-203(1 piece)
- Spring constant 49.3N/mm(5.02kgf/mm)

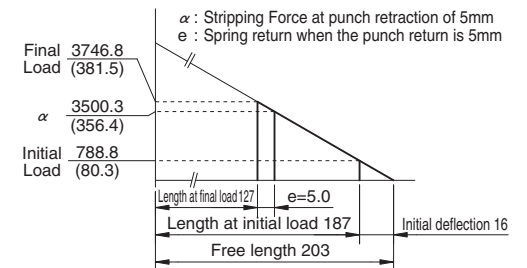

Bolts and dowel pins for assembly are not indicated. Part numbers are shown on the drawing.