

- 500 to 1000 (at increments of 100 mm) are available for the mount width.
- Available angles is 0°, 5°, 10°, 15° and 20°.
- Gas spring can be installed for returning Cam Slider.
- Spring can be removed from back without disassembling of Cam.

⚠ Up to 1600mm width can be supplied.
Please contact sales representative.

Slide Structure and Positive Return Structure

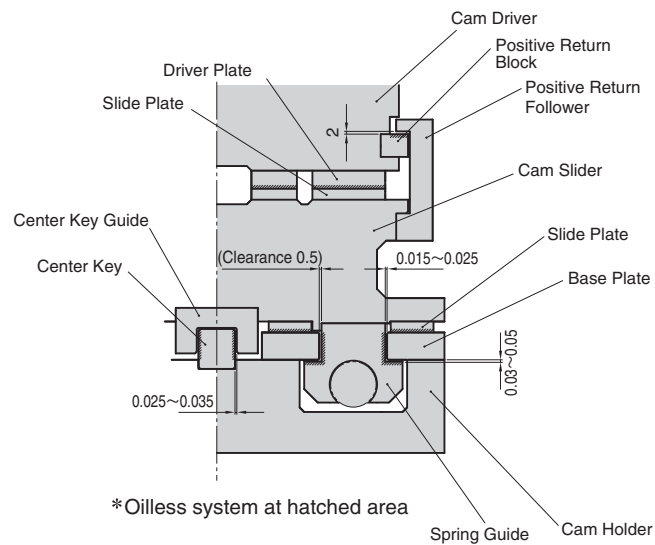

- Sliding system by Box Guide, Clearance between Cam Slider and Cam Holder is 0.015~0.025 on one side.

⚠ Nitrogen gas is not filled in case of air delivery
(Option Code : -NF)

KCMSL Structure and Assembly / Disassembly

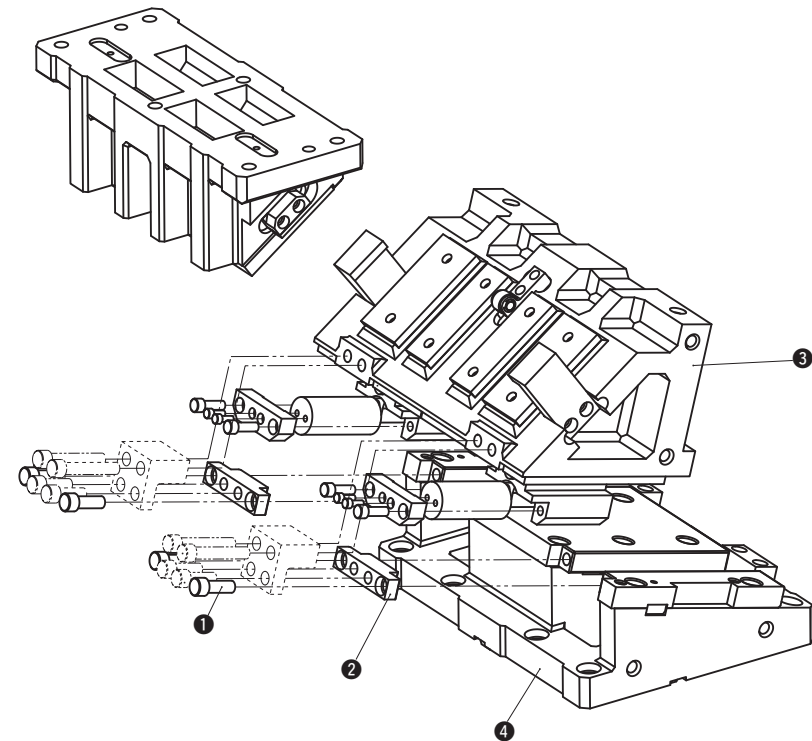

Disassembly Method of KCMSL

- 1) Loosen hexagon socket head bolt (1) and remove stopper plate (2).
- 2) Pull and remove cam slider (3) from cam holder (4).

Assembly Method of KCMSL

- 1) Assemble components in the reverse order of disassembly.
 - Make sure that there is no foreign matter on the sliding area and assemble components.
 - The clearance between the cam slider and the cam holder is controlled. Match the stamped serial number on the holder and slider before assembly.
 - When cam is disassembled and then reassembled, please do not forget to assemble all bolts provided

KCMSL900-00 / KCMSL1000-00

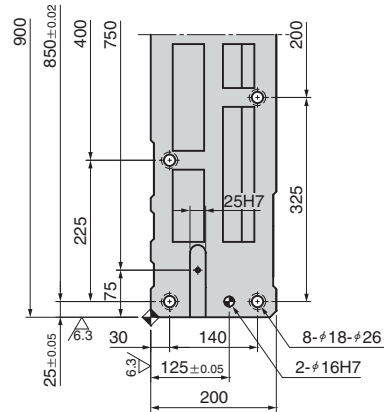

Cam Diagram

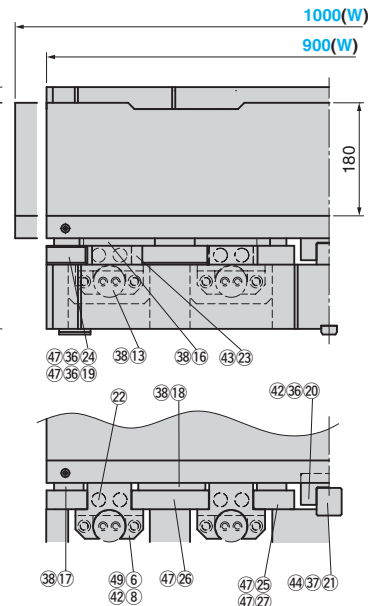
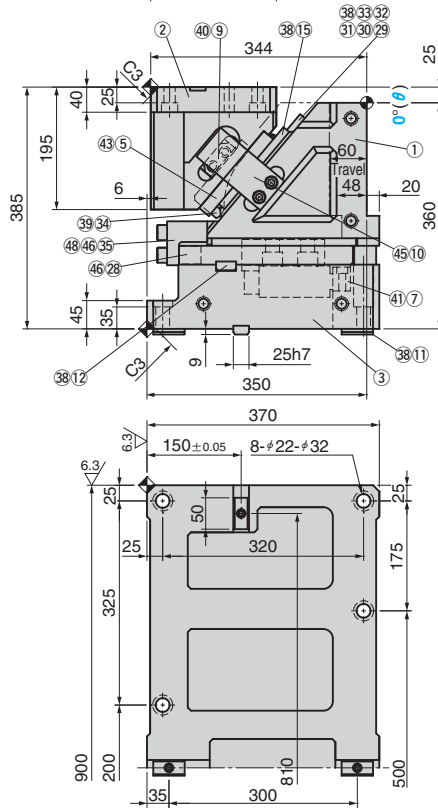
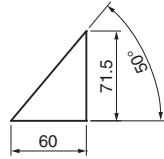

* If springs are not required, specify NGK by putting N at the top of spring type GK. Parts for spring installation are accompanied.

Travel S	Working Force kN(tonf)	Spring Force kN(tonf)		Catalog No.	(W)	(θ)	Spring Type G
		Initial Load	Final Load				
60.0	627.2 (64.0)	0.0 (0.0)	39.2 (4.0)	KCMSL	900 1000	00	GK
		-	-				NGK*



Order

Catalog No.	(W)	(θ)	G
KCMSL	900	00	GK
KCMSL	1000	00	NGK

.....Without gas spring



Option

Option Code	Specification
NF	Nitrogen gas is not charged. Applicable to GK only.



Order

KCMSL900-00-GK-NF

Spring Specification

No.	Type	Model	Remark
13	GK	K750-80	by KALLER

Weight(kg)

(W)	Slider Weight	Total Weight
900	276.0	571
1000	283.9	579

Space for removing

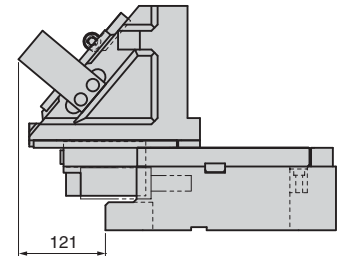

Refer to page 1772 for the table of components.

Die Mounted Cam Unit

LARGE TYPE FOR PIERCE AND FLANGE

Addition

KCMSL900-05 / KCMSL1000-05

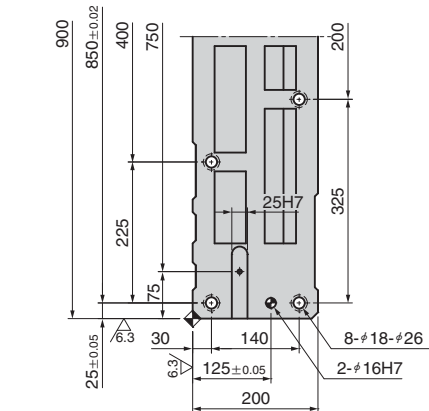

Cam Diagram

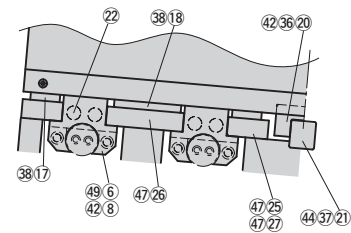
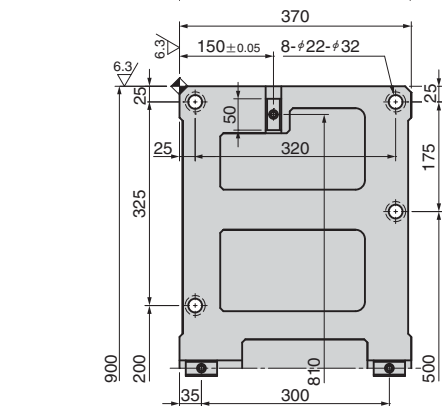
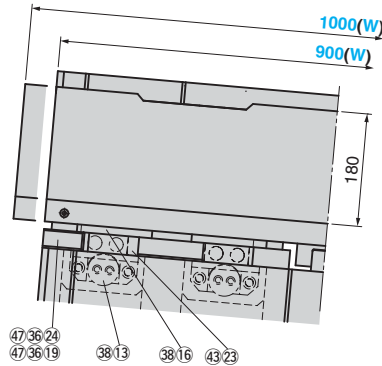
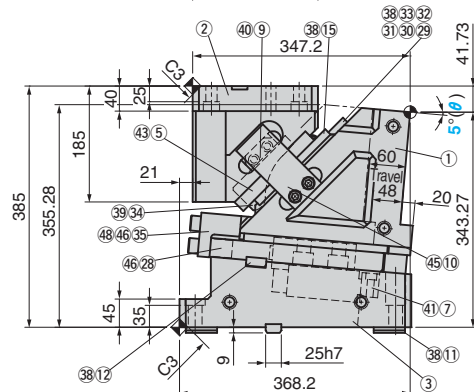
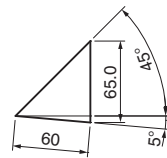

Travel S	Working Force kN(tonf)	Spring Force kN(tonf)		Catalog No.	(W)	(θ)	Spring Type G
		Initial Load	Final Load				
60.0	627.2 (64.0)	0.0 (0.0)	39.2 (4.0)	KCMSL	900 1000	05	GK
		-	-				NGK*

* If springs are not required, specify NGK by putting N at the top of spring type GK. Parts for spring installation are accompanied.



Order

Catalog No.	(W)	(θ)	G
KCMSL	900	05	GK
KCMSL	1000	05	NGK

.....Without gas spring



Option

Option Code	Specification
NF	Nitrogen gas is not charged. Applicable to GK only.



Order

KCMSL900-05-GK-NF

Spring Specification

No.	Type	Model	Remark
13	GK	K750-80	by KALLER

Weight(kg)

(W)	Slider Weight	Total Weight
900	276.0	560
1000	283.9	569

Space for removing

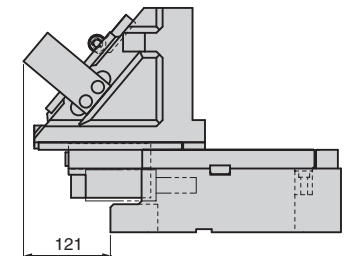

Refer to page 1772 for the table of components.

Die Mounted Cam Unit

LARGE TYPE FOR PIERCE AND FLANGE

Addition

KCMSL900-10 / KCMSL1000-10

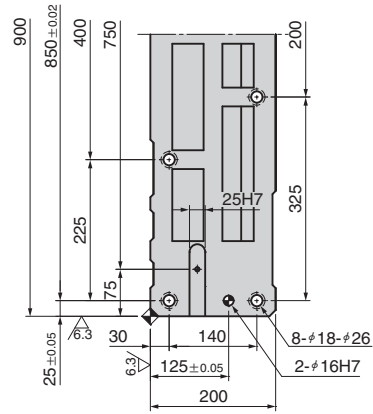

Cam Diagram

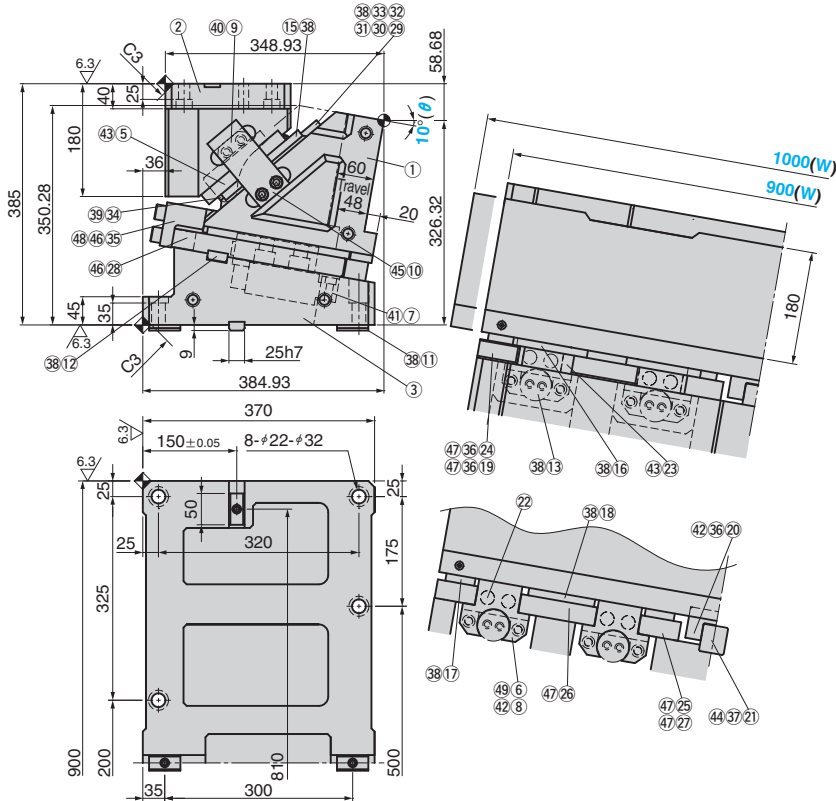
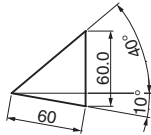

Travel S	Working Force kN(tonf)	Spring Force kN(tonf)		Catalog No.	(W)	(θ)	Spring Type G
		Initial Load	Final Load				
60.0	627.2 (64.0)	0.0 (0.0)	39.2 (4.0)	KCMSL	900 1000	10	GK
		-	-				NGK*

* If springs are not required, specify NGK by putting N at the top of spring type GK. Parts for spring installation are accompanied.



Order

Catalog No.	(W)	(θ)	G
KCMSL	900	10	GK
KCMSL	1000	10	NGK

.....Without gas spring



Option

Option Code	Specification
NF	Nitrogen gas is not charged. Applicable to GK only.



Order

KCMSL900-10-GK-NF

Spring Specification

No.	Type	Model	Remark
13	GK	K750-80	by KALLER

Weight(kg)

(W)	Slider Weight	Total Weight
900	276.0	551
1000	283.9	560

Space for removing

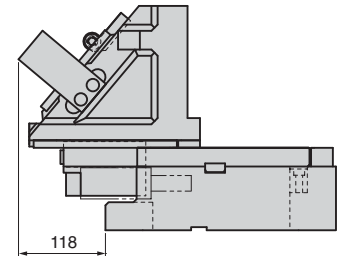

Refer to page 1772 for the table of components.

Die Mounted Cam Unit

LARGE TYPE FOR PIERCE AND FLANGE

Addition

KCMSL900-15 / KCMSL1000-15

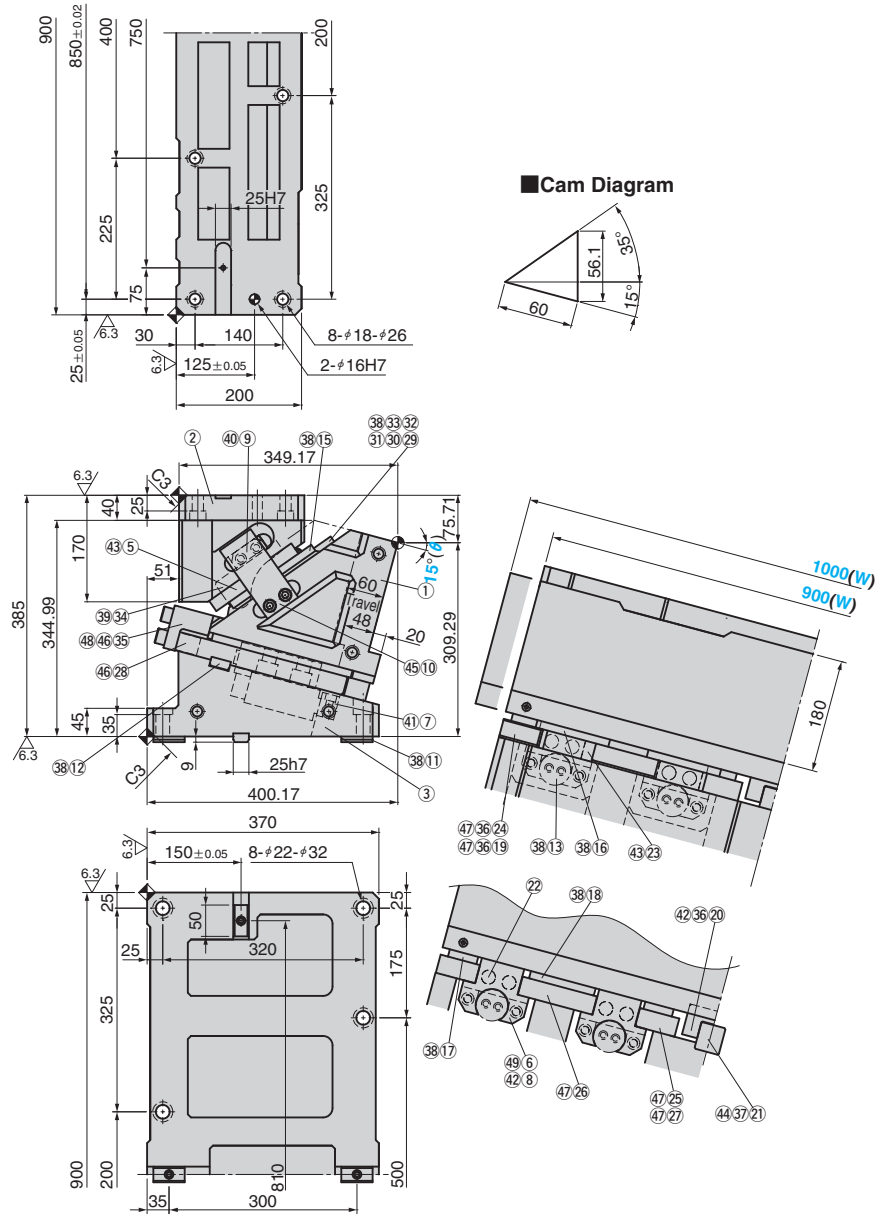

Travel S	Working Force kN(tonf)	Spring Force kN(tonf)		Catalog No.	(W)	(θ)	Spring Type
		Initial Load	Final Load				G
60.0	627.2 (64.0)	0.0 (0.0)	39.2 (4.0)	KCMSL	900 1000	15	GK
		-	-				NGK*

* If springs are not required, specify NGK by putting N at the top of spring type GK. Parts for spring installation are accompanied.



Order

Catalog No.	(W)	(θ)	G
KCMSL	900	15	GK
KCMSL	1000	15	NGK

.....Without gas spring



Option

Option Code	Specification
NF	Nitrogen gas is not charged. Applicable to GK only.



Order

KCMSL900-15-GK-NF

Spring Specification

No.	Type	Model	Remark
13	GK	K750-80	by KALLER

Weight(kg)

(W)	Slider Weight	Total Weight
900	276.0	543
1000	283.9	551

Space for removing

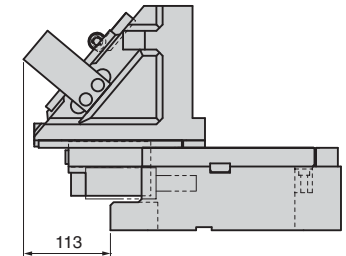

Refer to page 1772 for the table of components.

Die Mounted Cam Unit

LARGE TYPE FOR PIERCE AND FLANGE

Addition

KCMSL900-20 / KCMSL1000-20

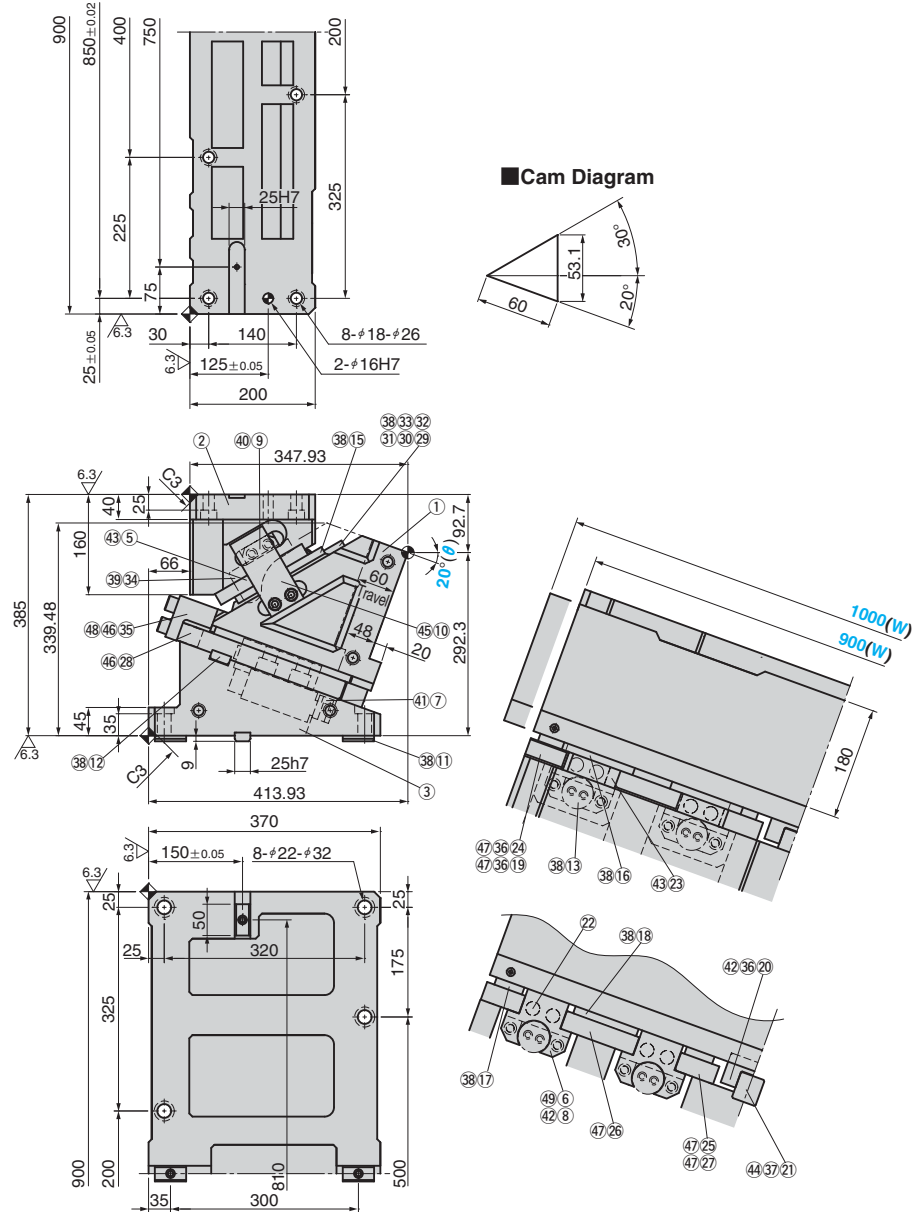

Travel S	Working Force kN(tonf)	Spring Force kN(tonf)		Catalog No.	(W)	(θ)	Spring Type G
		Initial Load	Final Load				
60.0	627.2 (64.0)	0.0 (0.0)	39.2 (4.0)	KCMSL	900 1000	20	GK
		-	-				NGK*

* If springs are not required, specify NGK by putting N at the top of spring type GK. Parts for spring installation are accompanied.



Order

Catalog No.	(W)	(θ)	G
KCMSL	900	20	GK
KCMSL	1000	20	NGK

.....Without gas spring



Option

Option Code	Specification
NF	Nitrogen gas is not charged. Applicable to GK only.



Order

KCMSL900-20-GK-NF

Spring Specification

No.	Type	Model	Remark
13	GK	K750-80	by KALLER

Weight(kg)

(W)	Slider Weight	Total Weight
900	276.0	536
1000	283.9	544

Space for removing

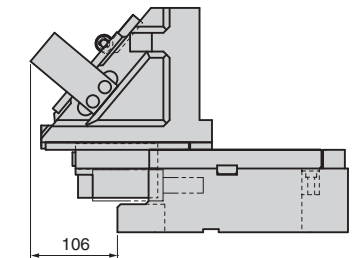

Refer to page 1772 for the table of components.

■ Table of Components (KCMSL500/600)

No.	Description	Qty	Material and Remark
①	Cam Slider	1	FC250
②	Cam Driver	1	FC250
③	Cam Holder	1	FC250
④	Cam Driver Plate A	2	Bronze with Graphite(SO#50 SP2)
⑤	Cam Driver Plate B	2	Bronze with Graphite(SO#50 SP2)
⑥	Spring Guide	2	Bronze with Graphite(SO#50 SP2)
⑦	Guide Pin Block	2	Steel
⑧	Spring Guide Plate	2	Steel
⑨	Positive Return Block	2	Bronze with Graphite(SO#50 SP2)
⑩	Positive Return Follower	2	S45C (1045 Hardened)
⑪	Key A	4	Steel
⑫	Key B	4	Steel
⑬	Gas Spring	2	Refer to the spring type table.
⑭	Lower Plate A	2	S45C (1045 Hardened)
⑮	Lower Plate B	2	S45C (1045 Hardened)
⑯	Slide Lower Plate A	2	Bronze with Graphite(SO#50 SP2)
⑰	Slide Lower Plate B	4	Bronze with Graphite(SO#50 SP2)
⑱	Center Key Guide	1	S45C (1045 Hardened)
⑲	Center Key Guide	1	Bronze with Graphite(SO#50 SP2)
⑳	Stopper	4	Urethane
㉑	Base Plate A	2	S45C (1045 Hardened)
㉒	Base Plate B	1	S45C (1045 Hardened)
㉓	Base Plate C	1	S45C (1045 Hardened)

■ Table of Components (KCMSL700/800)

No.	Description	Qty	Material and Remark
①	Cam Slider	1	FC250
②	Cam Driver	1	FC250
③	Cam Holder	1	FC250
④	Cam Driver Plate A	2	Bronze with Graphite(SO#50 SP2)
⑤	Cam Driver Plate B	4	Bronze with Graphite(SO#50 SP2)
⑥	Spring Guide	2	Bronze with Graphite(SO#50 SP2)
⑦	Guide Pin Block	2	Steel
⑧	Spring Guide Plate	2	Steel
⑨	Positive Return Block	2	Bronze with Graphite(SO#50 SP2)
⑩	Positive Return Follower	2	S45C (1045 Hardened)
⑪	Key A	4	S45C (1045 Hardened)
⑫	Key B	6	Steel
⑬	Gas Spring	2	Refer to the spring type table.
⑭	Lower Plate A	2	S45C (1045 Hardened)
⑮	Lower Plate B	4	S45C (1045 Hardened)
⑯	Slide Lower Plate A	2	Bronze with Graphite(SO#50 SP2)
⑰	Slide Lower Plate B	2	Bronze with Graphite(SO#50 SP2)
⑱	Slide Lower Plate D	2	Bronze with Graphite(SO#50 SP2)
⑲	Center Key Guide	1	S45C (1045 Hardened)
㉑	Center Key Guide	1	Bronze with Graphite(SO#50 SP2)
㉒	Stopper	4	Urethane
㉓	Base Plate A	2	S45C (1045 Hardened)
㉔	Base Plate B	1	S45C (1045 Hardened)
㉕	Base Plate B	1	S45C (1045 Hardened)

No.	Description	Qty	Material and Remark
㉖	Base Plate B	1	S45C (1045 Hardened)
㉗	Base Plate C	1	S45C (1045 Hardened)
㉘	Stopper Plate	2	Steel
㉙	Roller Bracket	1	Steel
㉚	Roller	1	S45C (1045 Hardened)
㉛	Roller Pin	1	S45C (1045 Hardened)
㉜	Bushing	1	SOB12-18-16
㉝	E Type Snap Ring	2	φ9
㉞	Roller Driver	1	S45C (1045 Hardened)
㉟	Lock Plate	2	Steel
㊱	Dowel Pin with Female Thread	6	SUJ2 φ12×40
㊲	Dowel Pin with Female Thread	2	SUJ2 φ12×50
㊳	Hexagon Socket Head Bolt	38	SCM435 M8×20
㊴	Hexagon Socket Head Bolt	2	SCM435 M10×25
㊵	Hexagon Socket Head Bolt	4	SCM435 M10×35
㊶	Hexagon Socket Head Bolt	2	SCM435 M10×45
㊷	Hexagon Socket Head Bolt	6	SCM435 M12×30
㊸	Hexagon Socket Head Bolt	12	SCM435 M12×35
㊹	Hexagon Socket Head Bolt	2	SCM435 M12×45
㊺	Hexagon Socket Head Bolt	4	SCM435 M12×50
㊻	Hexagon Socket Head Bolt	8	SCM435 M16×40
㊼	Hexagon Socket Head Bolt	8	SCM435 M16×45
㊽	Hexagon Socket Head Bolt	4	SCM435 M16×90
㊾	Hexagon Socket Head Bolt	6	SCM435 M16×55

No.	Description	Qty	Material and Remark
㉖	Base Plate E	1	S45C (1045 Hardened)
㉗	Base Plate E	1	S45C (1045 Hardened)
㉘	Stopper Plate	2	Steel
㉙	Roller Bracket	1	Steel
㉚	Roller	1	S45C (1045 Hardened)
㉛	Roller Pin	1	S45C (1045 Hardened)
㉜	Bushing	1	SOB12-18-16
㉝	E Type Snap Ring	2	φ9
㉞	Roller Driver	1	S45C (1045 Hardened)
㉟	Lock Plate	2	S45C (1045 Hardened)
㊱	Dowel Pin with Female Thread	6	SUJ2 φ12×40
㊲	Dowel Pin with Female Thread	2	SUJ2 φ12×50
㊳	Hexagon Socket Head Bolt	50	SCM435 M8×20
㊴	Hexagon Socket Head Bolt	2	SCM435 M10×25
㊵	Hexagon Socket Head Bolt	4	SCM435 M10×35
㊶	Hexagon Socket Head Bolt	2	SCM435 M10×45
㊷	Hexagon Socket Head Bolt	6	SCM435 M12×30
㊸	Hexagon Socket Head Bolt	16	SCM435 M12×35
㊹	Hexagon Socket Head Bolt	2	SCM435 M12×45
㊺	Hexagon Socket Head Bolt	4	SCM435 M12×50
㊻	Hexagon Socket Head Bolt	8	SCM435 M16×40
㊼	Hexagon Socket Head Bolt	12	SCM435 M16×45
㊽	Hexagon Socket Head Bolt	4	SCM435 M16×90
㊾	Hexagon Socket Head Bolt	6	SCM435 M16×55

■ Table of Components (KCMSL900/1000)

No.	Description	Qty	Material and Remark
①	Cam Slider	1	FC250
②	Cam Driver	1	FC250
③	Cam Holder	1	FC250
⑤	Cam Driver Plate B	7	Bronze with Graphite(SO#50 SP2)
⑥	Spring Guide	4	Bronze with Graphite(SO#50 SP2)
⑦	Guide Pin Block	4	Steel
⑧	Spring Guide Plate	4	Steel
⑨	Positive Return Block	2	Bronze with Graphite(SO#50 SP2)
⑩	Positive Return Follower	2	S45C (1045 Hardened)
⑪	Key A	4	Steel
⑫	Key B	6	Steel
⑬	Gas Spring	4	Refer to the spring type table.
⑮	Lower Plate B	7	S45C (1045 Hardened)
⑯	Slide Lower Plate A	4	Bronze with Graphite(SO#50 SP2)
⑰	Slide Lower Plate B	4	Bronze with Graphite(SO#50 SP2)
⑱	Slide Lower Plate C	2	Bronze with Graphite(SO#50 SP2)
⑲	Base Plate B	1	S45C (1045 Hardened)
㉑	Center Key Guide	1	S45C (1045 Hardened)
㉒	Center Key Guide	1	Bronze with Graphite(SO#50 SP2)
㉓	Stopper	8	Urethane
㉔	Base Plate A	4	S45C (1045 Hardened)
㉕	Base Plate B	1	S45C (1045 Hardened)
㉖	Base Plate C	1	S45C (1045 Hardened)

No.	Description	Qty	Material and Remark
㉖	Base Plate D	2	S45C (1045 Hardened)
㉗	Base Plate C	1	S45C (1045 Hardened)
㉘	Stopper Plate	4	Steel
㉙	Roller Bracket	2	Steel
㉚	Roller	2	S45C (1045 Hardened)
㉛	Roller Pin	2	S45C (1045 Hardened)
㉜	Bushing	2	SOB12-18-16
㉝	E Type Snap Ring	4	φ9
㉞	Roller Driver	2	S45C (1045 Hardened)
㉟	Lock Plate	2	Steel
㊱	Dowel Pin with Female Thread	6	SUJ2 φ12×40
㊲	Dowel Pin with Female Thread	2	SUJ2 φ12×50
㊳	Hexagon Socket Head Bolt	66	SCM435 M8×20
㊴	Hexagon Socket Head Bolt	4	SCM435 M10×25
㊵	Hexagon Socket Head Bolt	4	SCM435 M10×35
㊶	Hexagon Socket Head Bolt	4	SCM435 M10×45
㊷	Hexagon Socket Head Bolt	10	SCM435 M12×30
㊸	Hexagon Socket Head Bolt	22	SCM435 M12×35
㊹	Hexagon Socket Head Bolt	2	SCM435 M12×45
㊺	Hexagon Socket Head Bolt	4	SCM435 M12×50
㊻	Hexagon Socket Head Bolt	12	SCM435 M16×40
㊼	Hexagon Socket Head Bolt	14	SCM435 M16×45
㊽	Hexagon Socket Head Bolt	4	SCM435 M16×90
㊾	Hexagon Socket Head Bolt	12	SCM435 M16×55