

SNR11 Series

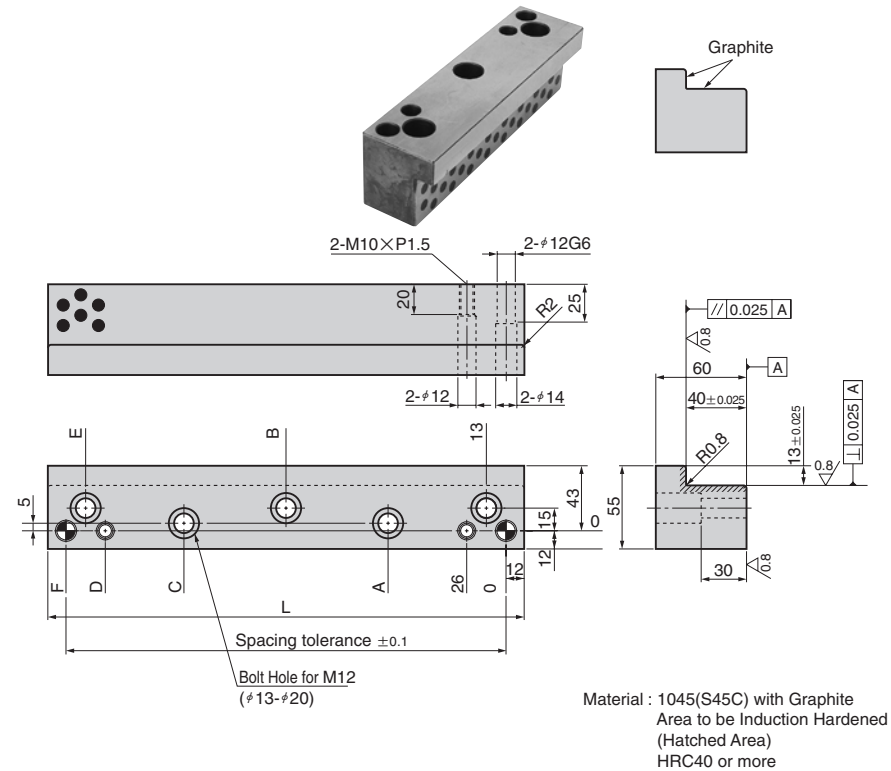

SNR12 Series

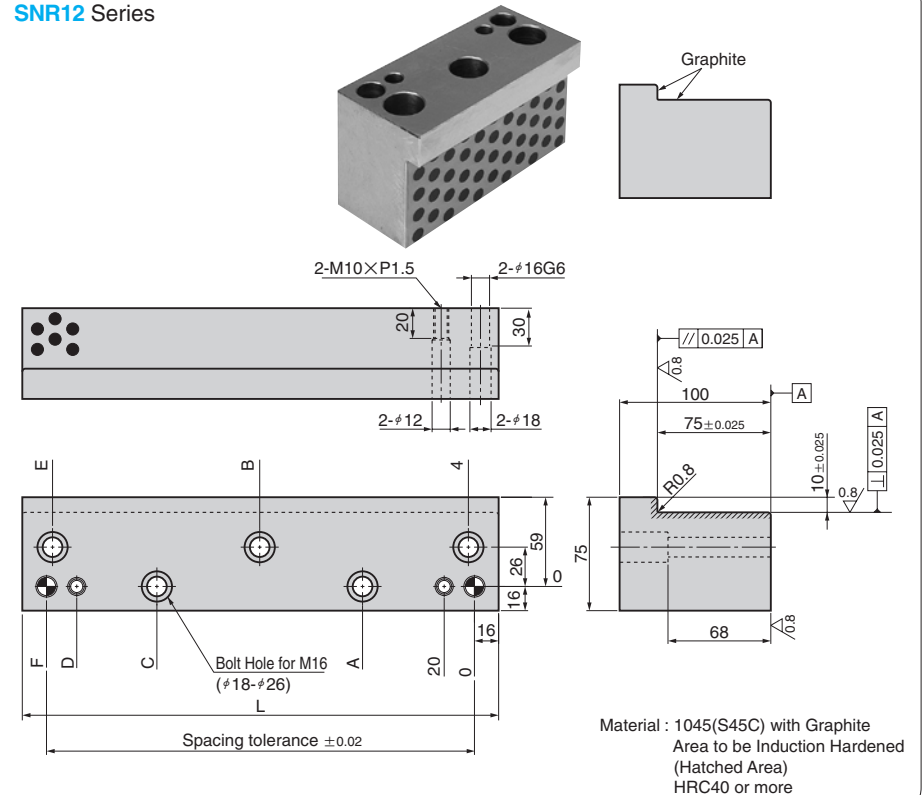

| No. of Holes | A | B | C | D | E | F | L | NAAMS Code | Catalog No. | |
|--------------|----|-------|-----|-----|-----|-----|-----|------------|-------------|------|
| | | | | | | | | | Series Name | No. |
| 3 | 68 | — | — | 110 | 123 | 136 | 160 | R114016 | SNR11 | 4016 |
| | 88 | — | — | 150 | 163 | 176 | 200 | R114020 | | 4020 |
| 4 | — | 148 | 200 | 213 | 226 | 250 | 315 | R114025 | | 4025 |
| 5 | 78 | 145.5 | 213 | 265 | 278 | 291 | 315 | R114031 | | 4031 |

| No. of Holes | A | B | C | D | E | F | L | NAAMS Code | Catalog No. | |
|--------------|----|-----|-----|-----|-----|-----|-----|------------|-------------|------|
| | | | | | | | | | Series Name | No. |
| 3 | — | 64 | — | 108 | 124 | 128 | 160 | R127516 | SNR12 | 7516 |
| | — | 84 | — | 148 | 164 | 168 | 200 | R127520 | | 7520 |
| 4 | — | 144 | 198 | 214 | 218 | 250 | 315 | R127525 | | 7525 |
| 5 | 74 | 142 | 210 | 263 | 279 | 283 | 315 | R127531 | | 7531 |



Order

Catalog No.

Series Name No.

SNR11 4016 (SNR114016)

▲ SNR11 Series is made to order.



Order

Catalog No.

Series Name No.

SNR12 7516 (SNR127516)

▲ SNR12 Series is made to order.