



# Cam Slide Guide V-Shaped Guide Type

NAAMS STANDARD

CAD FILE

## U Block

SNG31 Series

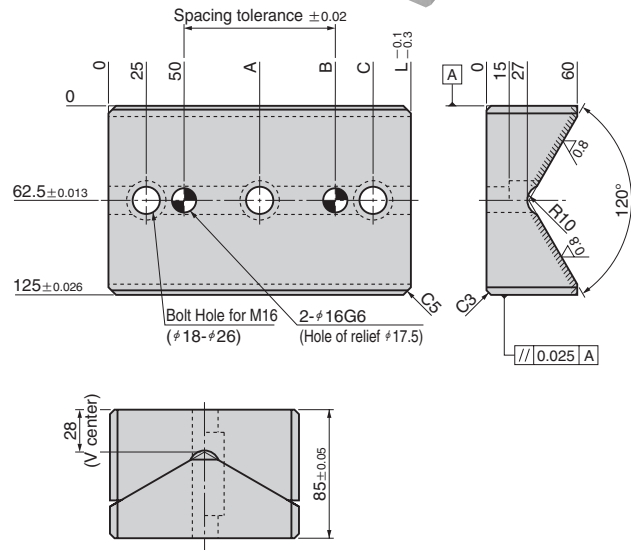
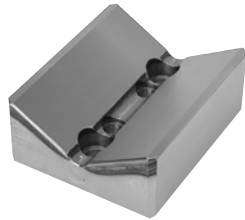

## V Block

SNG32 (Steel with Graphite) Series  
SNG33 (Bronze with Graphite) Series

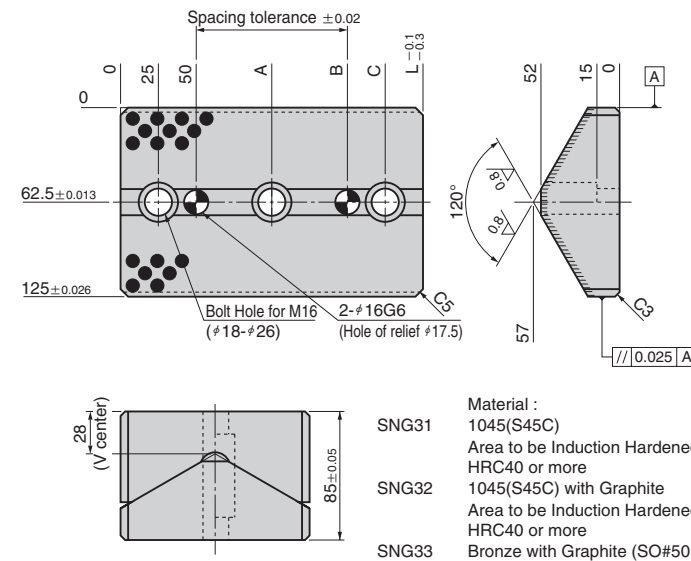
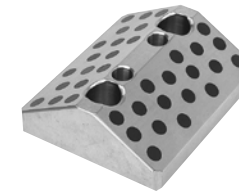

No. of Holes	L	A	B	C	NAAMS Code	Catalog No.	
						Series Name	No.
2	150	—	100	125	G311215	SNG31	1215
	200	—	150	175	G311220		1220
3	250	125	200	225	G311225		1225
	300	150	250	275	G311230		1230

No. of Holes	L	A	B	C	NAAMS Code		Catalog No.		
					Steel Type	Bronze Type	Series Name	No.	
2	150	—	100	125	G321215	G331215	SNG32	1215	
	200	—	150	175	G321220	G331220		1220	
3	250	125	200	225	G321225	G331225		SNG33	1225
	300	150	250	275	G321230	G331230			1230



Order

Catalog No.

Series Name  No.

SNG31 1225 (SNG311225)

⚠ SNG31 Series is made to order.



Order

Catalog No.

Series Name  No.

SNG32 1225 (SNG321225)

⚠ SNG32/33 Series is made to order.