

Guide Post

NAAMS STANDARD

CAD FILE

SNG51 Series

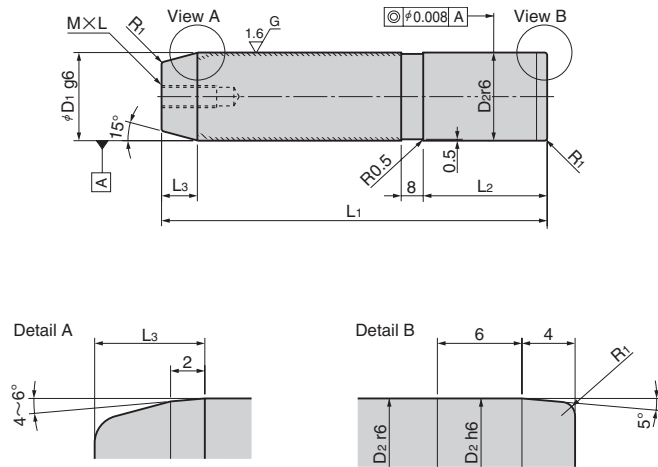

Material : 1045(S45C)
 Area to be Induction Hardened
 (Hatched Area)
 HRC57 to 62

D1	D2	L1	L2	L3	R1	M×L	NAAMS Code	Catalog NO.	
								Series Name	No.
25	25	80	40	8	2		G512508		2508
		100					G512510		2510
		125					G512512		2512
		140					G512514		2514
		160					G512516		2516
		180					G512518		2518
32	32	100	45	8	2		G513210		3210
		125					G513212		3212
		140					G513214		3214
		160					G513216		3216
		180					G513218		3218
		200					G513220		3220
40	40	160	56	8	2	M8×20	G514016		4016
		180					G514018		4018
		200					G514020		4020
		225					G514022		4022
		250					G514025		4025
		160					G515016		5016
50	50	180	70	10	2.5		G515018		5018
		200					G515020		5020
		225					G515022		5022
		250					G515025		5025
		280					G515028		5028
		315					G515031		5031
63	63	200	80	10	2.5		G516320	SNG51	6320
		225					G516322		6322
		250					G516325		6325
		280					G516328		6328
		315					G516331		6331
		355					G516335		6335
80	80	400	100	10	3		G516340		6340
		500					G516350		6350
		250					G518025		8025
		280					G518028		8028
		315					G518031		8031
		355					G518035		8035
100	100	400	125	10	3		G518040		8040
		500					G518050		8050
		315					G511031		1031
		355					G511035		1035
		400					G511040		1040
		500					G511050		1050
115	115	400	140	10	3	M12×30	G511140		1140
		500					G511150		1150
		400					G511240		1240
		450					G511245		1245
		500					G511250		1250
		550					G511255		1255
125	125	600	140	10	3		G511260		1260
		650					G511265		1265
		700					G511270		1270



Order

Catalog No.



SNG51 Series is made to order.

Series Name

No.

SNG51

2508

(SNG512508)