

General Description of Transfer Conveyor Unit

FOR PRE-DRAW

Structure of Transfer Conveyor Unit

The transfer conveyor unit consists of the ① Drive conveyor unit at drive side, ② Secondary conveyor unit at driven side and ③ Universal joint connecting both sides.

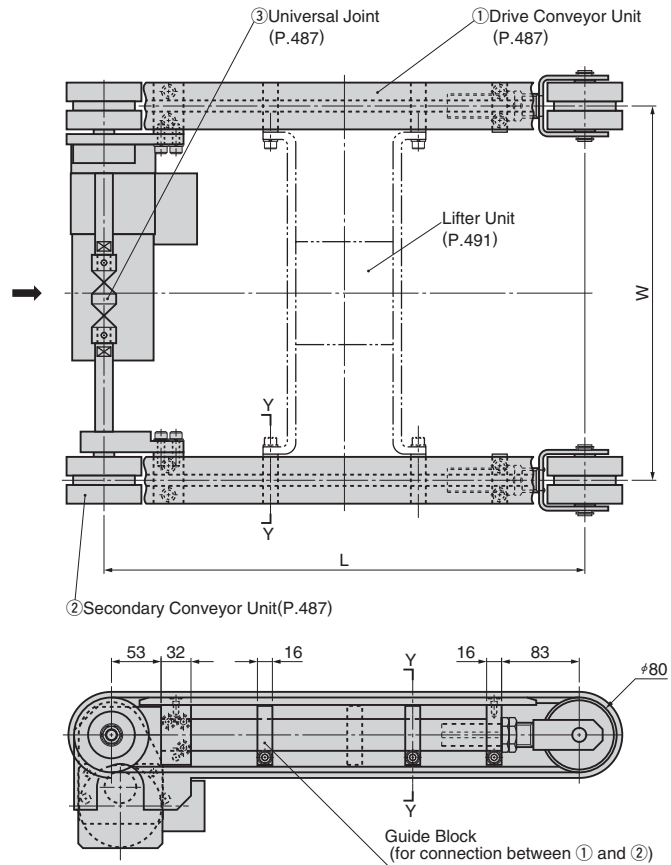

Details of drive conveyor unit ①

Description	Details
Drive Unit	Motor, gearbox, Pulley, Shaft
Tension Unit	Tension Pulley, Adjuster
Frame	Frame Pipe, Belt Guide, Guide Block
Belt	Belt with Special Sponge

Details of secondary conveyor unit ②

Description	Details
Driven Unit	Pulley, Bearing, Shaft
Tension Unit	Tension Pulley, Adjuster
Frame	Frame Pipe, Belt Guide, Guide Block
Belt	Belt with Special Sponge

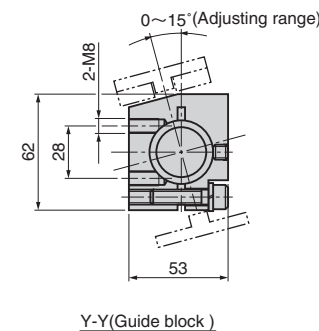
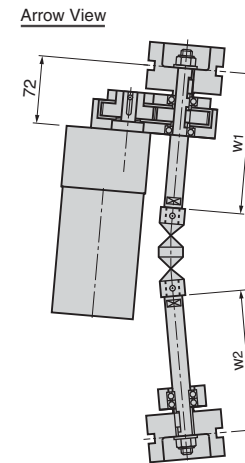

Motor mounting angle (option)

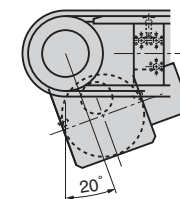

● Angle of 20 degrees can be specified
 (Refer to the order method page of the drive conveyor unit. P.487)

Layout of Transfer Conveyor Unit

The transfer conveyor unit has 4 layout patterns below.

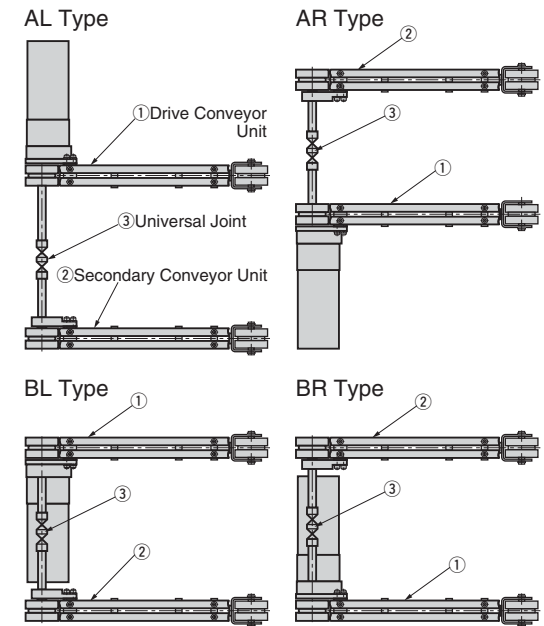

For Design

	Layout Type	
	AL and AR	BL and BR
L	200 ~ 1000	
W(min)	243	283
W(max)	1100	
w1(Drive Conveyor)	40 ~ 200	80 ~ 200
w2(Secondary Conveyor)	60 ~ 200	

- Length of the universal joint can be specified. For details, refer to page 487.
- For detailed dimensions, refer to the CAD data. Download the CAD data from our web site or ask it from your nearest sales office.
- The belt with special sponge is available as standard part. It may be changed according to the specification of the customer.

Transfer Conveyor Unit

CONVEYER UNIT



■ Drive Conveyor Unit (①)

DRVAL (Layout Type AL)
DRVAR (Layout Type AR)
DRVBL (Layout Type BL)
DRVBR (Layout Type BR)

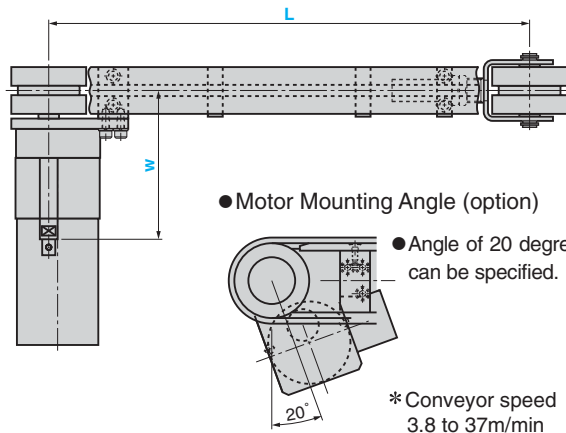

■ Secondary Conveyor Unit (②)

CNVAL (Layout Type AL)
CNVAR (Layout Type AR)
CNVBL (Layout Type BL)
CNVBR (Layout Type BR)

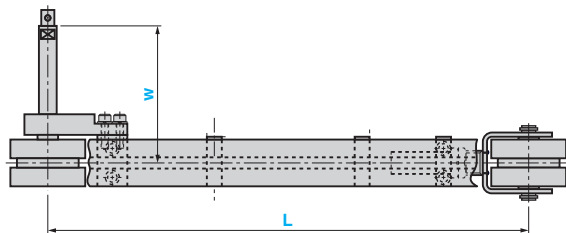

■ Universal Joint (③)

UNVJ
 (Fixed length and key coupling type)

UNVJL
 (Variable length and dowel pin coupling type)

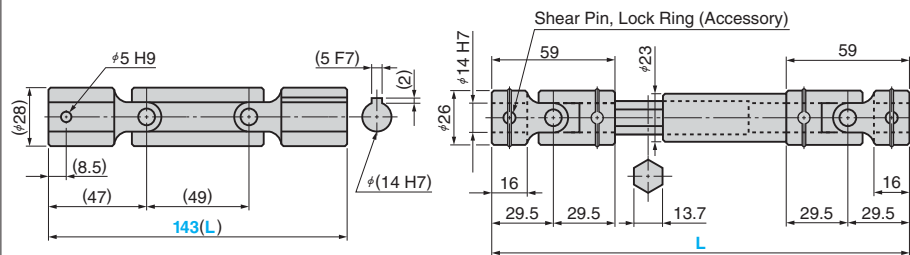

Catalog No.	L Increments of 100 mm	w Increments of 10 mm		Motor Type (by Oriental)
		DRVAL DRVAR	DRVBL DRVBR	
DRVAL DRVAR DRVBL DRVBR	200 ~ 1000	40 ~ 200	80 ~ 200	MB (AC100V : FBL575AW-20) MC (AC200V : FBL5120CW-30)



Order **Catalog No.** **L** - **w** - **Motor Type** - **Option**
DRVAL **800** - **120** - **MB** - **KC**

*Angle can be specified for the option. Give **-KC** if the angle is required.

Catalog No.	L Increments of 100 mm	w Increments of 10 mm	Shaft Type (Joint Type)
CNVAL CNVAR CNVBL CNVBR	200 ~ 1000	60 ~ 200	K (Key Joint) P (Dowel Pin Joint)



Order **Catalog No.** **L** - **w** - **Shaft Type**
CNVBR **700** - **80** - **K**

Catalog No.	L Increments of 10 mm
UNVJ	143
UNVJL	200 ~ 1100



Order **Catalog No.** **L**
UNVJ **143**
UNVJL **650**

Stopper Unit

FOR PRE-DRAW

CAD
FILE

HPSTP

* This drawing shows the option ⑧ proximity switch bracket mounted at the right side.

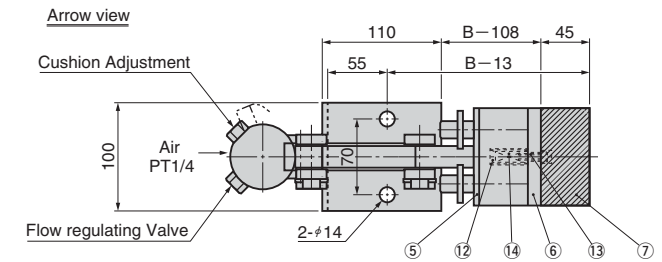
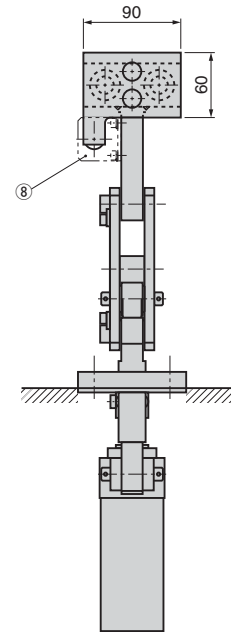
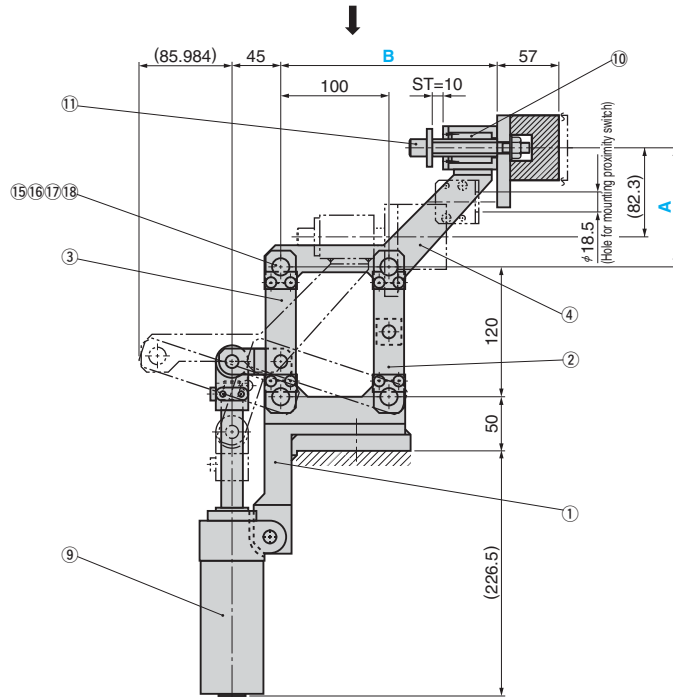

Table of Components

No.	Description	Qty	Material and Remark
①	Bracket	1	SS400
②	Link	1	SS400
③	Arm	1	SS400
④	Bracket	1	SS400
⑤	Plate	1	SPHC
⑥	Plate	1	SS400
⑦	Stopper	1	Urethane
⑧	Proximity Switch Bracket	1	SPC-C
⑨	Air Cylinder	1	By SMC
⑩	Linear Bushing	2	
⑪	Shoulder Bolt	2	S45C SCM435
⑫	Spring	1	SWP-A
⑬	Shoulder Bolt	2	SCM435
⑭	Dowel Pin	1	SUJ2
⑮	Dry Busing	4	Bronze Type Sintered
⑯	Dry Washer	8	Bronze Type Sintered
⑰	Hinge Pin	4	S45C
⑱	Key	4	SS400

Catalog No.	A Increments of 5 mm	B Increments of 5 mm
HPSTP	100 ~ 150	170 ~ 205

Order

Catalog No.	A	-	B
HPSTP	125	-	175



Option

Option Code	Specification
R	⑧ Proximity switch is mounted. Specify either R or L.
L	



Order

HPSTP125-175-R

Transfer Conveyor Movement Lifter Unit

FOR PRE-DRAW

CAD FILE

HPEJT

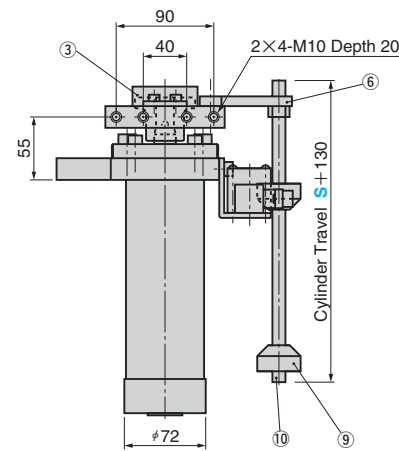
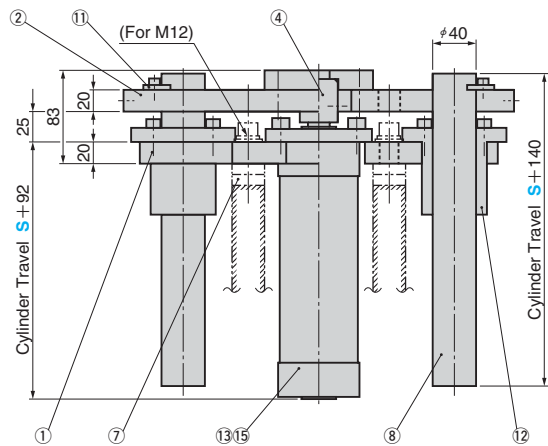
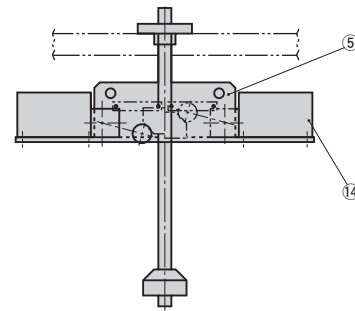
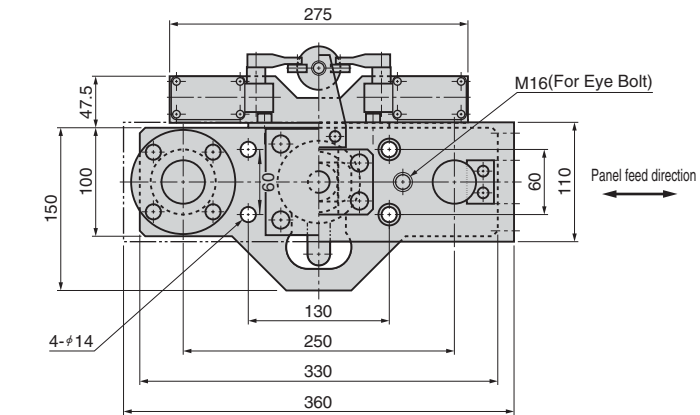

Table of Components

No.	Description	Qty	Material and Remark
①	Base Plate	1	SS400
②	Upper Plate	1	SS400
③	Knuckle Cover	1	SS400
④	Knuckle	1	S50C
⑤	Limit Switch Bracket	1	SS400
⑥	Dog Plate	1	SS400
⑦	Liner(t=10)	4	SS400
⑧	Linear Shaft	2	SUJ2 SFAK By Misumi
⑨	Dog	2	SS400
⑩	Dog Shaft	1	SS400
⑪	Key	2	SS400
⑫	Linear Bushing	2	SMF40UU By NB
⑬	Air Cylinder	1	CG1FA63 By SMC
⑭	Limit Switch	2	1LS71-JSW2 By Yamatake
⑮	Connector	2	12R-02S1 Hose diameter φ12 By Chiyoda

Catalog No.	S
	100
	125
	150
HPEJT	175
	200
	250
	300



Order

Catalog No.	S
HPEJT	100