

Driver

FOR PRE-DRAW

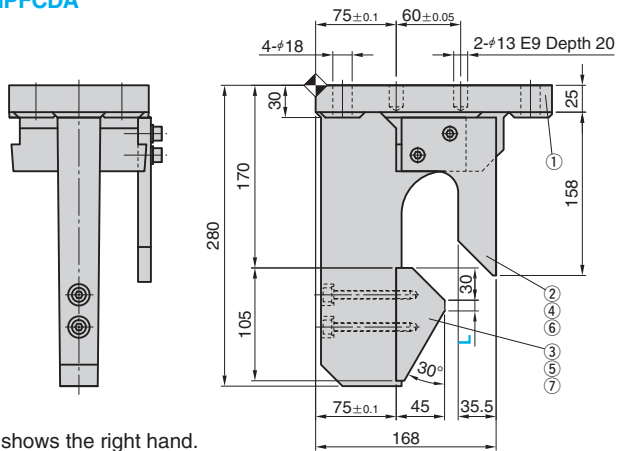

HPFCDA



*This drawing shows the right hand.
The left hand is symmetric to this drawing.

HPFCDB

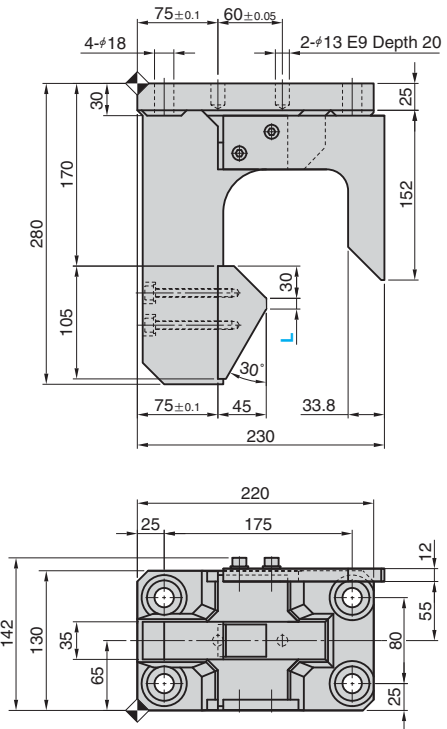

Table of Components

No.	Description	Qty	Material and Remark
①	Driver	1	FCD600
②	Plate	1	SS400
③	Cam	1	S50C HRC50
④	Hexagon Socket Head Bolt	2	SCM435 M10×30
⑤	Hexagon Socket Head Bolt	2	SCM435 M8×75
⑥	Spring Washer	2	For M10
⑦	Spring Washer	2	For M8

Catalog No.	L	R / L
HPFCDA	10 15	R and L
HPFCDB	20 25	

Table for Link Unit and Driver

Link Unit			Driver
HPSL	HPPL45	HPPL55	HPFCDA
HPPC			HPFCDB



Order

Catalog No.	L	-	R / L
HPFCDA	25	-	L

Driver

FOR PRE-DRAW

NEW CAD FILE

MEMO

HPCDF

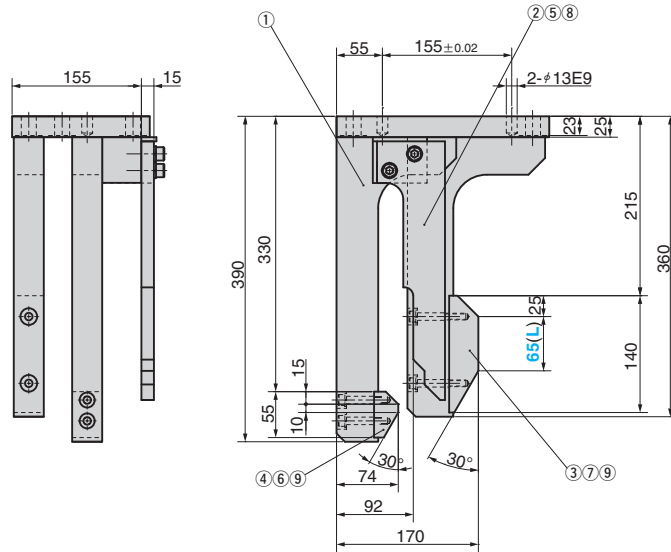
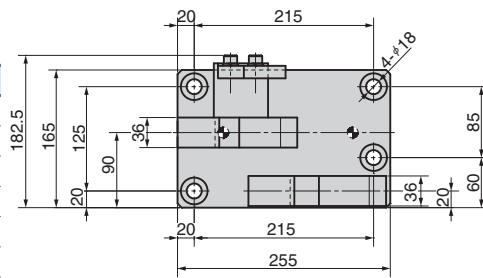

Table of Components

No.	Description	Qty	Material and Remark
①	Driver	1	SS400
②	Plate	1	SS400
③	Cam A	1	S50C
④	Cam B	1	S50C
⑤	Hexagon Socket Head Bolt	2	SCM435 M10×30
⑥	Hexagon Socket Head Bolt	2	SCM435 M8×50
⑦	Hexagon Socket Head Bolt	2	SCM435 M8×55
⑧	Spring Washer	2	For M10
⑨	Spring Washer	4	For M8



*This drawing shows the right hand.
The left hand is symmetric to this drawing.

Catalog No.	(L)	R/L
HPCDF	65	R and L

Table for Link Unit and Driver

Link Unit	Driver
HPPWF	HPCDF



Order

Catalog No. (L) - R/L
HPCDF 65 - L