

HPPC

*The drawing portrays the right side.
The left side is also symmetrical.

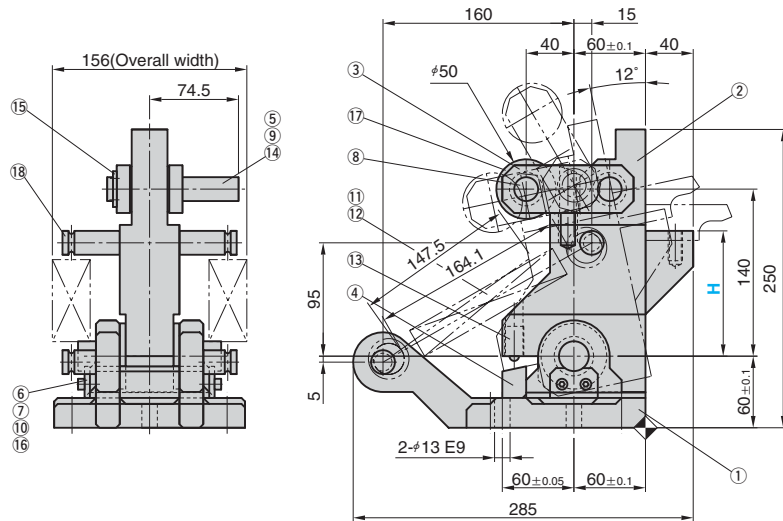
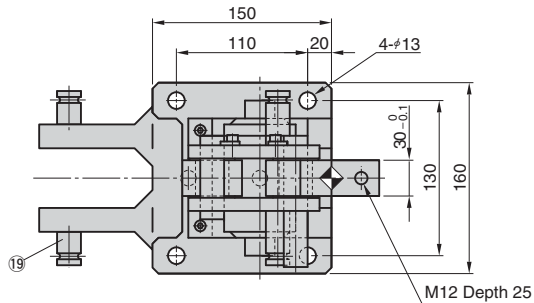
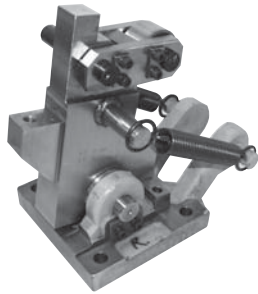
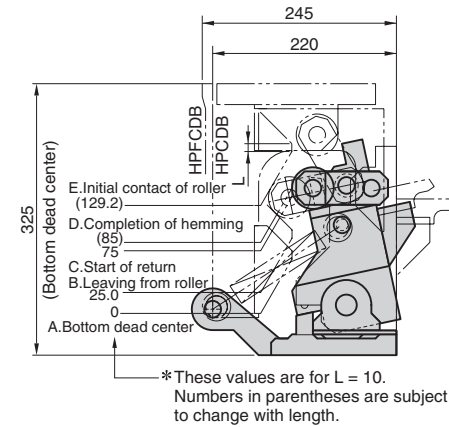

Table of Components

No.	Description	Qty	Material and Remark
①	Base	1	FCD600
②	Swing Arm	1	SS400
③	H Link	1	S50C
④	Stopper	1	SS400
⑤	Oilless Bushing	2	Bronze with Graphite (SO#50 SP2)
⑥	Oilless Bushing	1	Bronze with Graphite (SO#50 SP2)
⑦	Oilless Washer	2	Bronze with Graphite (SO#50 SP2)
⑧	Hinge Pin	1	S45C
⑨	Hinge Pin	1	S45C
⑩	Hinge Pin	1	S45C
⑪	Spring	2	SWP-A
⑫	Ring	4	SS400
⑬	Ball Plunger	2	
⑭	Dry Washer	4	Bronze Sintered
⑮	Key	2	SS400
⑯	Key	1	SS400
⑰	Roller	1	S50C
⑱	Casting Pin	1	S45C
⑲	Casting Pin	2	S45C

Operation between Driver and Unit



Spring Force

Free Length (mm)	Initial Length (mm)	Initial Tensile Force N(kgf)	Final Length (mm)	Final Tensile Force N(kgf)
138.0	148.0	97.5×2 (10.0×2)	164.5	148.0×2 (15.1×2)

Catalog No.	H Increments of 5 mm	R / L
HPPC	40 ~ 140	R and L

Order -

The drivers conforming to this link unit are HPCDB and HPFCDB.(P.477 to P.480)