

Scrap Lifter

FOR SCRAP CUTTING

CAD FILE

PIKS

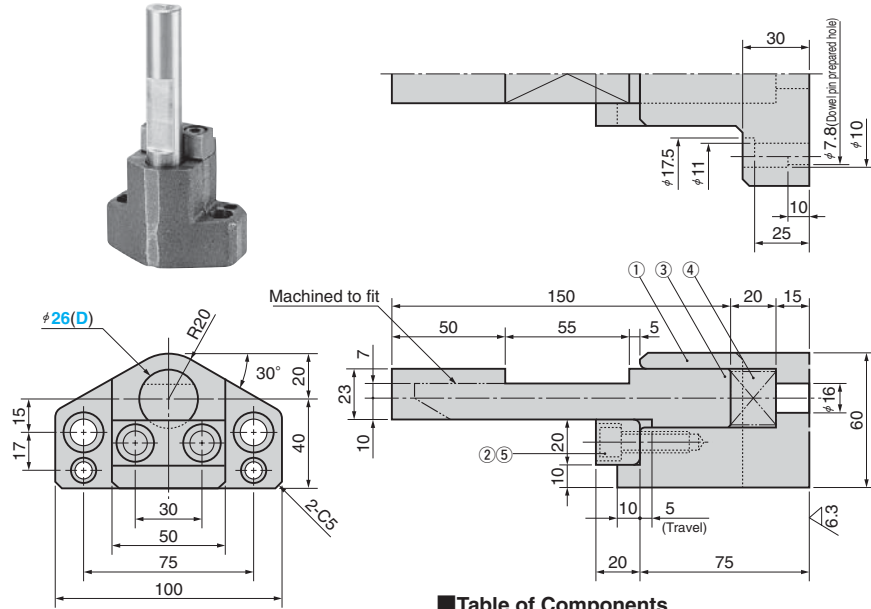
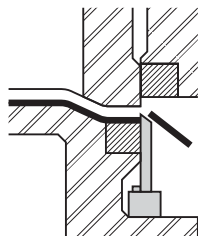

Table of Components

No.	Description	Qty	Material and Remark
①	Holder	1	FC250
②	Stopper	1	FC250 with Graphite
③	Slide Pin	1	S45C (HRC23 to 28)
④	Spring	1	SUP φ25×40
⑤	Hexagon Socket Head Bolt	2	SCM435 M10×30

④ Spring		Catalog No.	(D)
Initial Load N	Final Load N		
49	66	PIKS	26

Order



Use this unit when a scrap tend to stick the cutter after cutting.

Emboss Plate

FOR SCRAP CHUTE

EMS

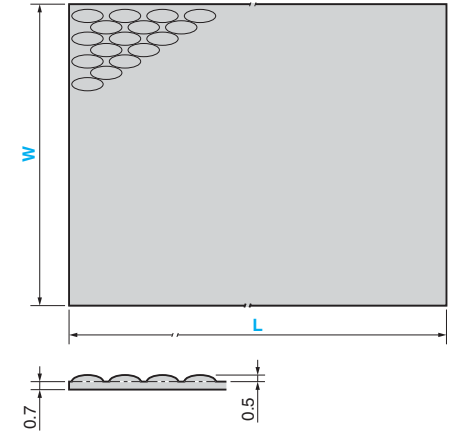
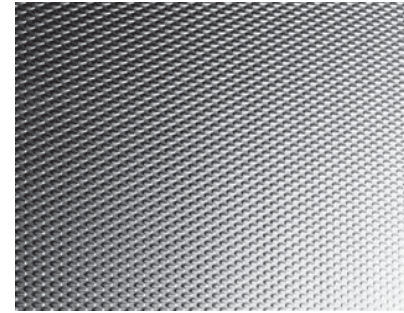

Material : SUS304

Catalog No.	W	L
EMS	1000	1000
		2000



Order

-

For Operation

- This plate has emboss dimples. Use the plate at the angle of 12° or more.
- Spot weld this plate on a normal scrap chute for use.
- The welding interval is approximately 150 to 200 mm.

