

BCBRA (Type with dowel hole for the center area)

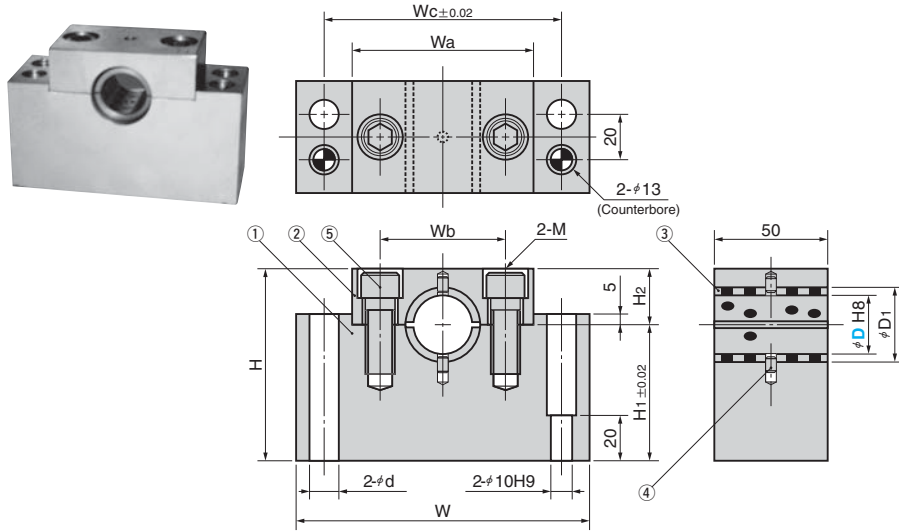

Table of Components

No.	Description	Qty	Material and Remark	No.	Description	Qty	Material and Remark
①	Case Body	1	SS400	④	Dowel Pin	2	SUJ2 φ5×10
②	Cap	1	SS400	⑤	Hexagon Socket Head Bolt	2	SCM435
③	Bushing (half)	1	FC250 with Graphite				

Catalog No.	D H8	W	Wa	Wb	Wc	H	H ₁	H ₂	D ₁	d	M
BCBRA	25	$+0.033$ 0	130	80	55	105	85	60	25	33	12
	35	$+0.039$ 0	170	110	75	140	105	70	35	18	16
	45	$+0.039$ 0	180	120	85	150	120	80	40	56	

Order

Catalog No.	D
BCBRA	35

⚠ Since the dowel hole position was changed, the catalog number was changed. If the left hand or right hand side is copied, the dowel pin position is not changed.

⚠ BCBRA is made to order.

BCBRB (Type with dowel hole for ends)

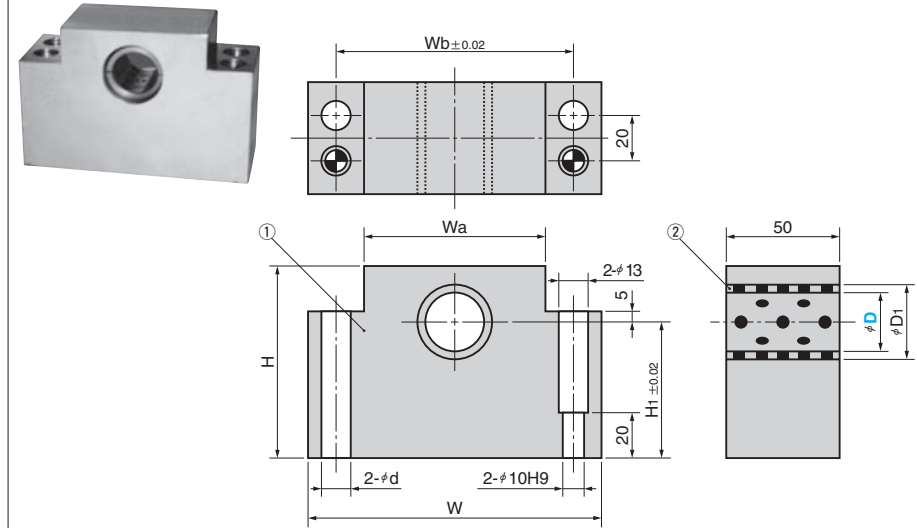

Table of Components

No.	Description	Qty	Material and Remark
①	Case Body	1	SS400
②	Bushing	1	Bronze with Graphite (SO#50 SP2)

Catalog No.	D Tolerance	W	Wa	Wb	H	H ₁	D ₁	d
BCBRB	25	$+0.025$ 0	130	80	105	85	60	33
	35	$+0.025$ 0	170	110	140	105	70	44
	45	$+0.030$ 0	180	120	150	120	80	56

Order

Catalog No.	D
BCBRB	35

⚠ Since the dowel hole position was changed, the catalog number was changed. If the left hand or right hand side is copied, the dowel pin position is not changed.

⚠ BCBRB is made to order.