

SOFLH50

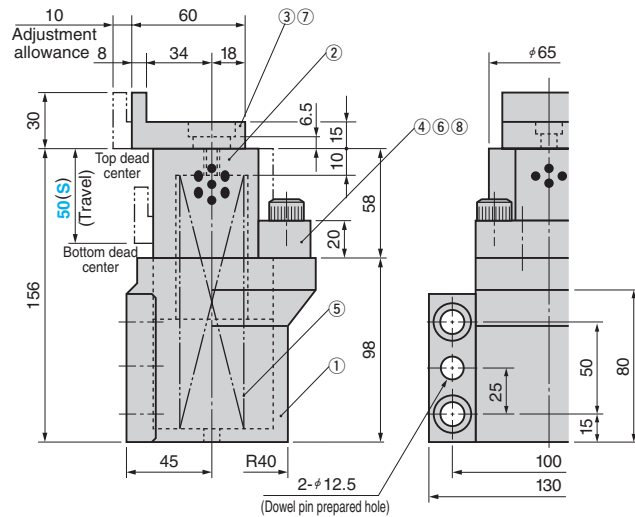
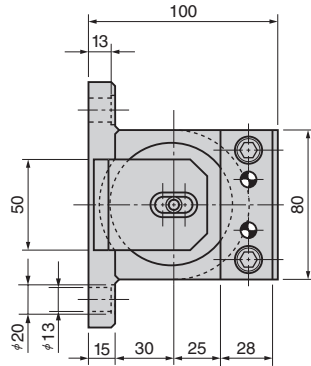

Table of Components

No.	Description	Qty	Material and Remark
①	Casing	1	FC250
②	Slide Pin	1	S20C with Graphite
③	Lift Block	1	SK3
④	Stopper	1	SK3 Hardness HRC40 to 45
⑤	Spring	1	TF35-150
⑥	Hexagon Socket Head Bolt	2	SCM435 M12×40
⑦	Hexagon Socket Head Bolt	1	SCM435 M8×20
⑧	Dowel Pin	2	SUJ2 φ8×30

Spring		Mounting		Final		Travel (mm)
Outer diameter(mm)	Free length(mm)	Length(mm)	Initial load(N)	Length (mm)	Maximum load(N)	
35	150	138	160	88	810	50

Catalog No.	(S)
SOFLH	50



Order

Catalog No.	(S)
SOFLH	50

Please refer to page 405 for option parts.