

### SOFLV50

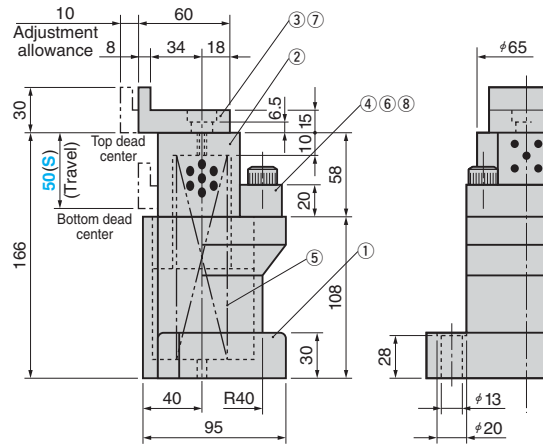
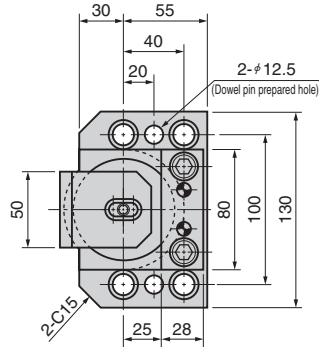

#### Table of Components

No.	Description	Qty	Material and Remark
①	Casing	1	FC250
②	Slide Pin	1	S20C with Graphite
③	Lift Block	1	SK3
④	Stopper	1	SK3 Hardness HRC40 to 4
⑤	Spring	1	TF35-150
⑥	Hexagon Socket Head Bolt	2	M12×40
⑦	Hexagon Socket Head Bolt	1	M8×20
⑧	Dowel Pin	2	φ8×30

### SOFLV80

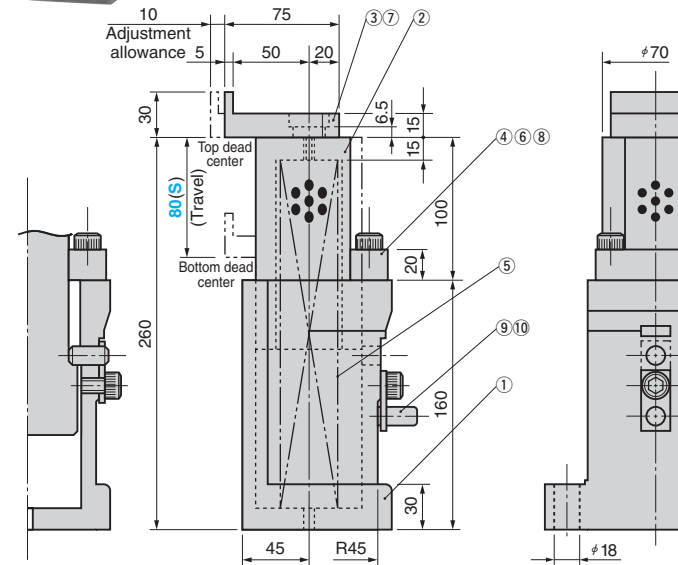
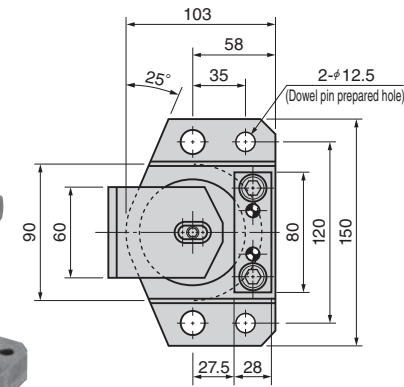
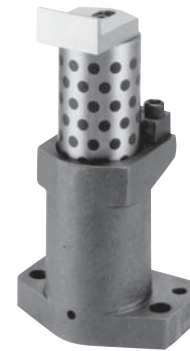

#### Table of Components

No.	Description	Qty	Material and Remark
①	Casing	1	FC250
②	Slide Pin	1	S20C with Graphite
③	Lift Block	1	SK3
④	Stopper	1	SK3 Hardness HRC40 ro 45
⑤	Spring	1	TF40-250
⑥	Hexagon Socket Head Bolt	2	M12×40
⑦	Hexagon Socket Head Bolt	1	M8×20
⑧	Dowel Pin	2	φ8×40
⑨	Lock Pin	1	SS400
⑩	Hexagon Socket Head Bolt	1	M10×16

Spring		Mounting		Final		Travel (mm)
Outer diameter(mm)	Free length(mm)	Length(mm)	Initial load(N)	Length (mm)	Maximum load(N)	
35	150	138	160	88	810	50

Catalog No.	(S)
SOFLV	50



Order

Catalog No.	(S)
SOFLV	50

Spring		Mounting		Final		Travel (mm)
Outer diameter(mm)	Free length(mm)	Length(mm)	Initial load(N)	Length (mm)	Maximum load(N)	
40	250	230	200	150	1020	80

Catalog No.	(S)
SOFLV	80



Order

Catalog No.	(S)
SOFLV	80