

# Lift Plate, Lift Gauge and Stabilizer Pin

FOR SUB LIFTER

CAD  
FILE

## LFTPA

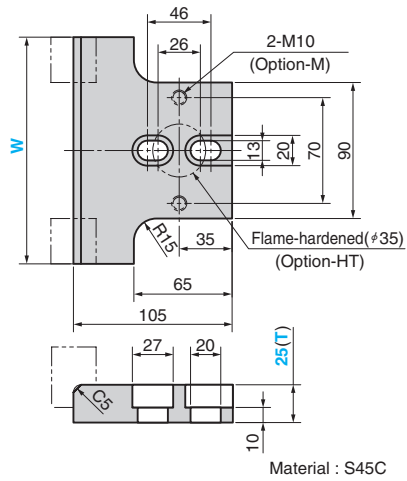

## LFTG

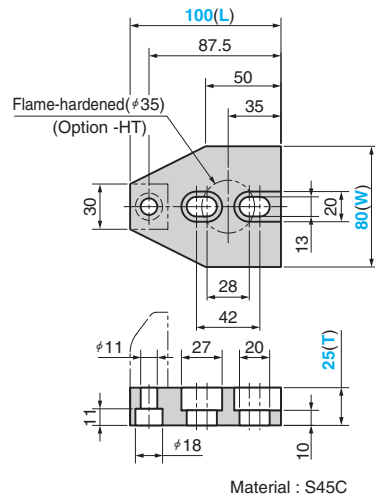

## LFTGA

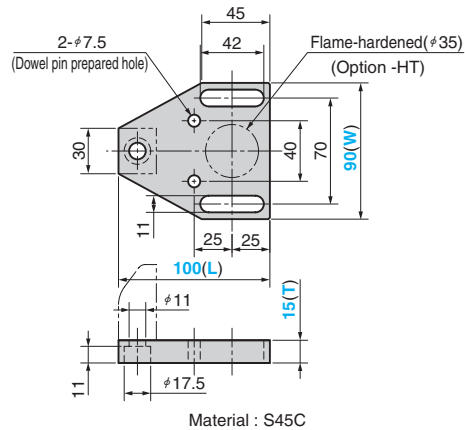

## FLPPA

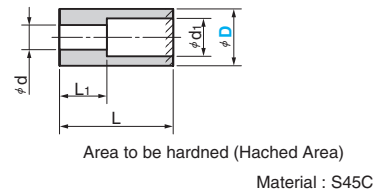

## Lift Plate LFTPA

Catalog No.	W	T
LFTPA	90~150 (in increments of 10 mm)	25

Order 

Catalog No.	W	T
LFTPA	110	25

▲ LFTPA, LFTG and LFTGA are the parts made to order.

## Gauge Plate LFTG·LFTGA

Catalog No.	W	L	T
LFTG	80	100	25
LFTGA	90	100	15

Order 

Catalog No.	W	L	T
LFTG	80	100	25
LFTGA	90	100	15



Option

Option Code	Specification
M	Tapped holes (2-M10) for the gauge plate are provided on lift plate LFTPA.
HT	The preliminary pin contact area is flame hardened. (Range φ 35)

\* Refer to the page on the left for detailed specifications.



Order

LFTPA	120-25-M
LFTG	80-100-25-HT

## Advance Pin FLPPA

d	d1	L1	Catalog No.	D	L at increments of 10 mm
9	14	20	FLPPA	25	40~60
		40			70~100
13	20	25		30	50·60
		45			70~100
		65			110~150

Order 

Catalog No.	D	L
FLPPA	30	100



Example

