

SBLFT

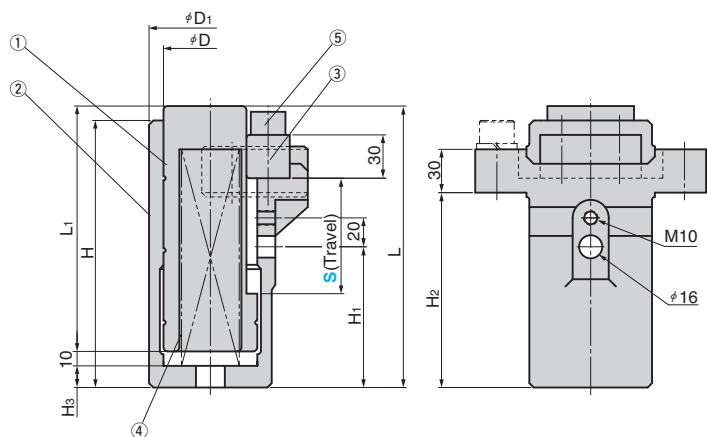
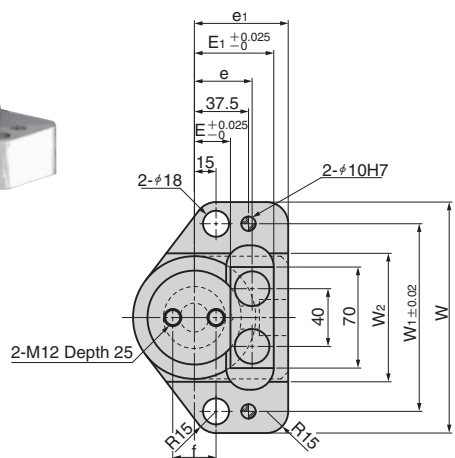

Table of Components

No.	Description	Qty	Material and Remark
①	Guide Post	1	FCD450
②	Holder	1	FC250
③	Stopper	1	FC250 with Graphite
④	Spring	1	SUP
⑤	Hexagon Socket Techno-Bolt	2	M16×50

S	D	D1	H	H1	H2	H3	L	L1	W	W1	W2	E	E1	e	e1	f
60	60	80	150	67.5	100		160	135	155	125	84					
80	65	85	185	97.5	135	15	195	170	160	130	89	25	55	40	65	30
120	75	95	240	122.5	190	20	260	230	170	140	100	30	60	45	70	40

Spring	Installation		Final		Catalog No.	S
	Length(mm)	Load(N)	Length(mm)	Load(N)		
TF40-200	180	250	120	1000		60
TF40-250	230	200	150	1000	SBLFT	80
TF50-350	330	224	210	1569		120



Order

Catalog No. S
SBLFT 80



Option

Option Code	Specification
D	Travel end stopper is provided.



Order **SBLFT 60 - D**

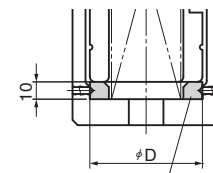

Travel end stopper

Lock Pin

SBLP16

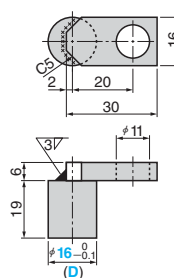

Material : SS400

Catalog No.	(D)
SBLP	16



Order

Catalog No. (D)
SBLP 16



Example

The mounting surface of the flange upper type lifter is located at the upper part of the holder. It is effective when the clearance between the sub-lifter and the part at the bottom dead center is small.

- As shown in Fig. 1, the sub-lifter can be mounted on the insert punch for an insert punch (CAP) type die. It is not necessary to remove the sub-lifter for each adjustment of the insert punch. In this way, labor hours can be saved.

- When the unit is mounted on the die lower die holder, rigidity of the die (lower die) can be improved by increasing the height of unit seating. (Fig. 2)

Fig. 1

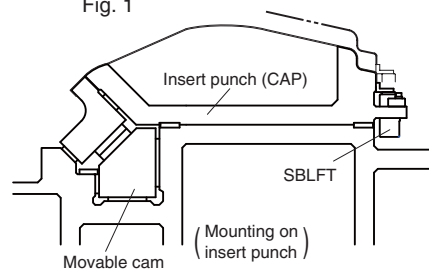

Fig. 2

