



SBLS

SBLSN  
(Slide Pin With Dowel Pin Hole)

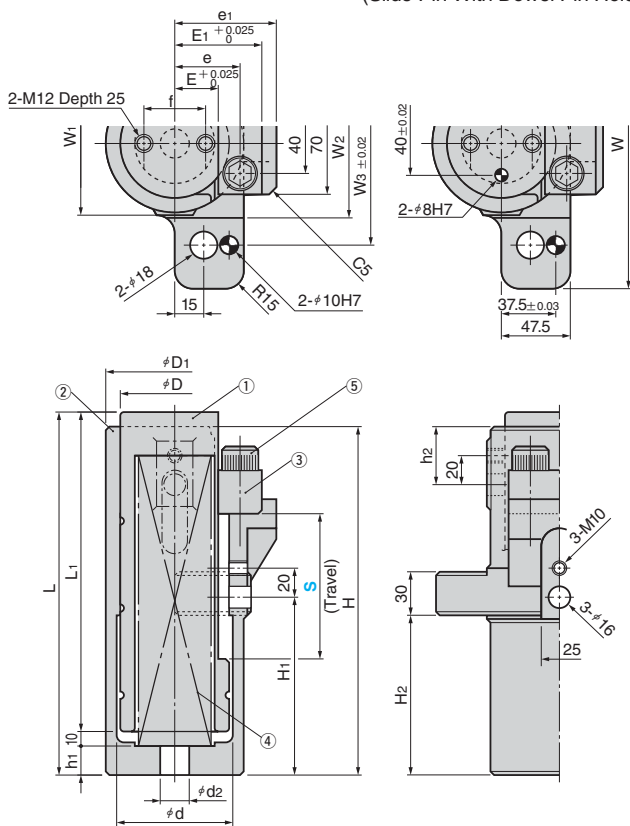

Table of Components

No.	Description	Qty	Material and Remark
①	Slide Pin	1	FCD450
②	Casing	1	FC250
③	Stopper	1	FC250 with Graphite
④	Spring	1	SWOSC-V By Tohatsu
⑤	Hexagon Socket Techno-Bolt	2	SCM435 M16×56 60

S	D	D1	d	d2	L	L1	H	H1	H2	h1	h2	E	e	E1	e1	f	W	W1	W2	W3
60	60	80	65	20	160	135	150	67.5	55	15	40	25	40	55	65	30	155	82	84	125
80	65	85	70	20	195	170	185	97.5	75	15	40	25	40	55	65	30	160	87	89	130
120	75	95	80	30	250	220	240	122.5	95	20	45	30	45	60	70	40	170	97	99	140

Spring	Installation		Final		Catalog No.	S
	Length(mm)	Load(N)	Length(mm)	Load(N)		
TF40-200	175	320	115	1088	SBLS SBLSN	60
D340-250	235	300	155	1900		80
TF50-350	320	342	200	1710		120



Order

Catalog No.	S
SBLS	80



Example

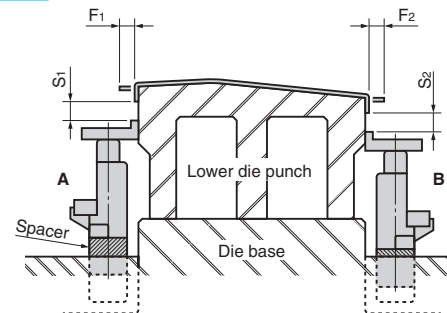

Lock Pin

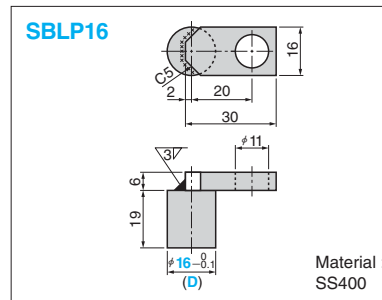

Catalog No.	(D)
SBLP	16



Order

Catalog No.	(D)
SBLP	16



Option

Option Code	Specification
D	Travel end stopper is provided.



Order

SBLSN 60 - D

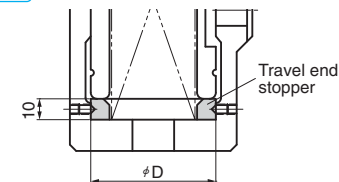

- Regardless of flange length  $F_1$  and  $F_2$ , make the clearances of  $S_1$  and  $S_2$  identical when the sub-lifter is at the bottom dead center so that the sub-lifter contact timing with the product may be adjusted.
- When  $F_1$  and  $F_2$  are different, the travels of sub-lifters A and B change. Adjust the length with spacers so that  $S_1$  and  $S_2$  may be identical.

Travel when the flange length is not constant.

$F_1 : 30\text{mm}$   $F_2 : 10\text{mm}$   
 Pad Travel PS: 70 mm Allowance  $\alpha : 10\text{ mm}$   
 Travel of A (SA)                      Stroke of B (SB)  
 $S_A = PS + F_1 + \alpha$                        $S_B = PS + F_2 + \alpha$   
 $= 70 + 30 + 10$                                $= 70 + 10 + 10$   
 $= 110$      $= 90$   
 $S_1 = 80$      $S_2 = 80$