

HLSGF

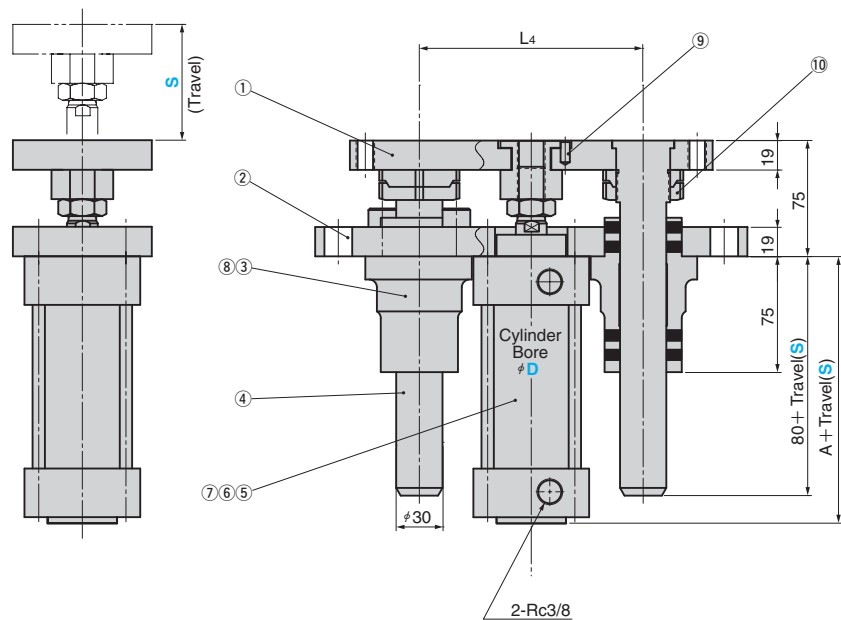
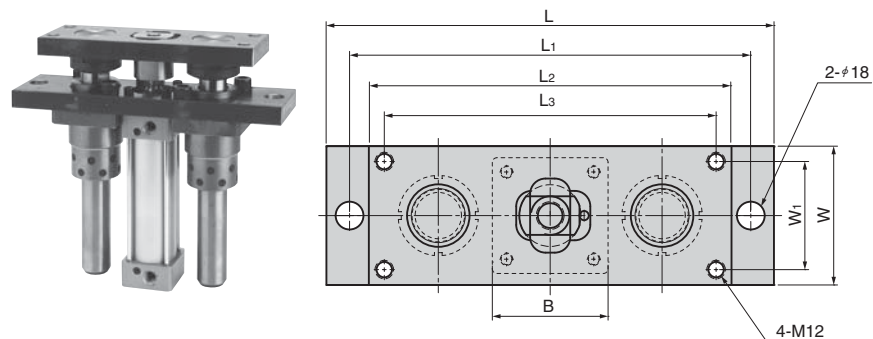

Table of Components

No.	Description	Qty	Material and Remark
①	Lifter Plate	1	SS400
②	Cylinder Holder Plate	1	SS400
③	Guide Holder	2	FC250 with Graphite
④	Guide Pin	2	S45C HRC55~60
⑤	Air Cylinder	1	MB40 (for D=40) by SMC MB63 (for D=63) by SMC

No.	Description	Qty	Material and Remark
⑥	Joint	1	S45C
⑦	Hexagon Socket Head Bolt	4	M6×35(for D=40) M8×35(for D=63)
⑧	Hexagon Socket Techno-Bolt	4	M12×35
⑨	Spring Pin	1	φ6×12
⑩	Hard Lock Nut	2	M35

A	B	Rc	L	L1	L2	L3	L4	W	W1	Catalog No.	Cylinder Bore D	Travel S
												50
												75
												100
												125
												150
88	52	1/4	270	240	215	190	120	75	45		40	175
												200
												225
												250
												275
										HLSGF		300
												50
												75
												100
												125
												150
98	75	3/8	290	260	235	215	145	90	70		63	175
												200
												225
												250
												275
												300

Order **Catalog No.** **D** - **S**
HLSGF 40 - 100

For Operation

Refer to the dimension of the casting hole below for installation.

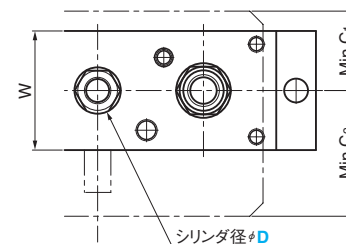

- Cylinder actual output
 Air pressure: 500 kPa
 φ40 : Approx. 600×0.7=420N
 φ63 : Approx. 1500×0.7=1050N

- If you want to use other cylinder type (different cylinder manufacturer), please contact our sales representative.

D	W	C1	C2
40	75	50	85
63	90	60	95