

HLSGC

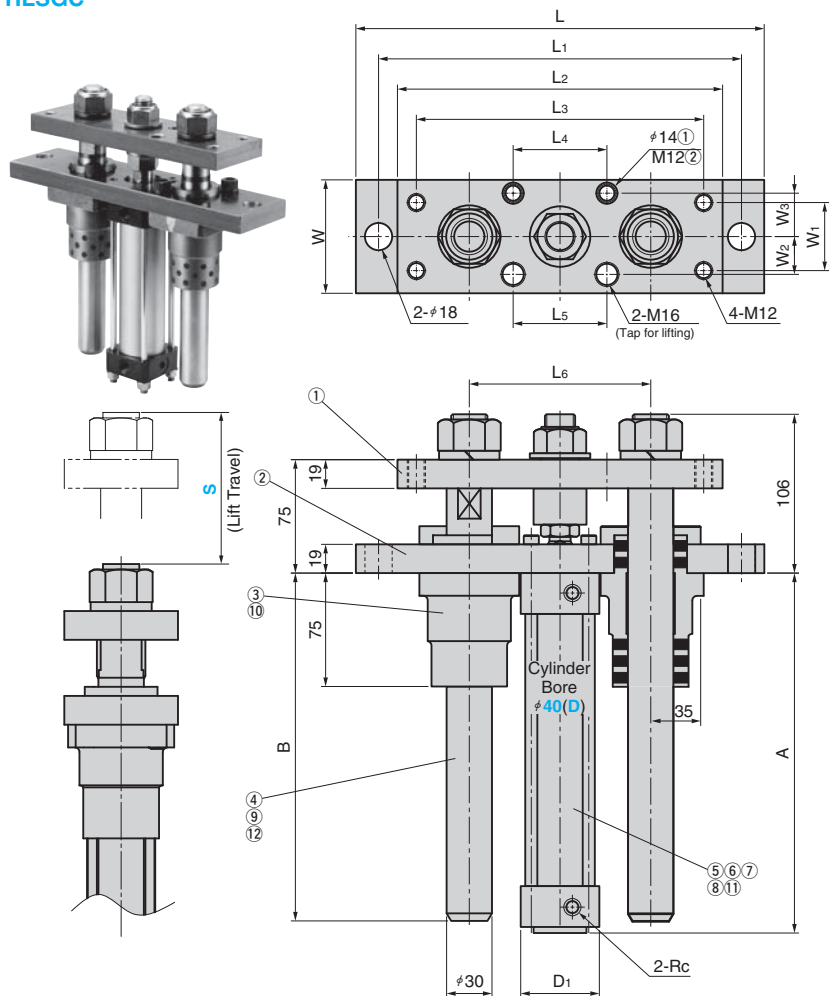

Table of Components

No.	Description	Qty	Material and Remark	No.	Description	Qty	Material and Remark
①	Lifter Plate	1	SS400	⑦	Hexagon Socket Head Bolt	4	SMC435 M6(For D=40) SMC435 M8(For D=63)
②	Cylinder Holder Plate	1	SS400	⑧	U Nut	1	M20
③	Guide Holder	2	FC250 with Graphite	⑨	U Nut	2	M24
④	Guide Pin	2	S45C HRC50~60	⑩	Hexagon Socket Techno-Bolt	4	SCM435 M12×35
⑤	Air Cylinder	1	MB40 by SMC(For D=40) MB63 by SMC(For D=63)	⑪	Flat Washer	1	For M20
⑥	Joint	1	SS400	⑫	Spring Washer	2	For M24

A	B	Rc	D1	L	L1	L2	L3	L4	L5	L6	W	W1	W2	W3	Catalog No.	Cylinder Bore D	Travel S
138	130																50
163	155																75
188	180																100
213	205																125
238	230																150
263	255	1/4	52	270	240	215	190	66	60	120	75	45	25	28		40	175
288	280																200
313	305																225
338	330																250
363	355																275
388	380																300
148	130														HLSGC		50
173	155																75
198	180																100
223	205																125
248	230																150
273	255	3/8	75	290	260	235	215	96	70	145	90	70	30	32		63	175
298	280																200
323	305																225
348	330																250
373	355																275
398	380																300



Order

Catalog No. (D) - S
HLSGC 40 - 150

•Cylinder actual output
Air pressure: 500 kPa
Approx. 600 × 0.7 = 420 N.

•If you want to use other cylinder types (different cylinder manufacturer), please contact our sales representative.

For Operation

Refer to the dimension of the casting hole below for installation.

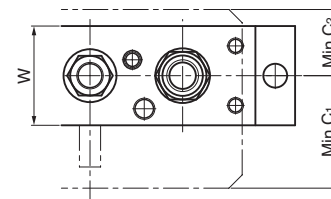

Cylinder Bore D	W	C1	C2
40	75	85	50
63	90	95	60