

- PSPCN (No Machining at End)
- PSPCS (Ball at End)
- PSPCU (Urethane at End)

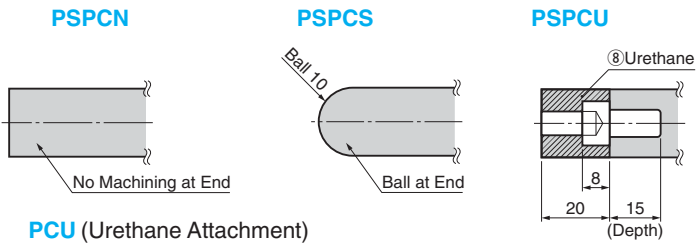

PCU (Urethane Attachment)

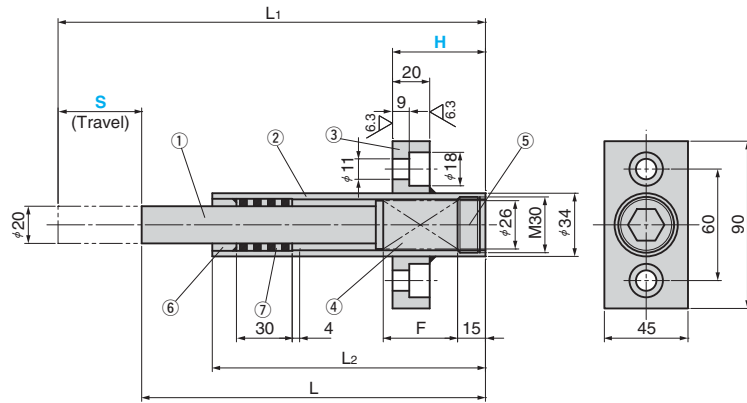
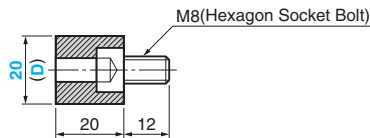

Table of Components

No.	Description	Qty	Material and Remark
①	Advance Pin	1	S45C HRC55 or more
②	Holder	1	STKM
③	Flange	1	SS400
④	Spring	1	SWOSC-V TR26
⑤	Screw Plug	1	SCM435 M30
⑥	Stopper	1	SS400
⑦	Guide Bushing	1	Bronze with Graphite SOB20-28-30
⑧	Urethane Attachment	1	Urethane(Shore A90)+Bolt

④ Spring		L	L ₁	L ₂	F	Catalog No.	Travel S	H Increments of 1 mm
TR26- 90		230	270	147	45	PSPCN PSPCS PSPCU	40	20 ≤ H ≤ L ₁
TR26-110	402.1	250	300	167	55		50	
TR26-125	(41.0)	270	330	185	63		60	
TR26-150		290	360	207	75		70	

Order -
PSPCN 50 - 30

Urethane attachment

Order
PCU 20