

Sheet Support Gauge

SHEET SUPPORT GAUGE

CAD
FILE

WKG

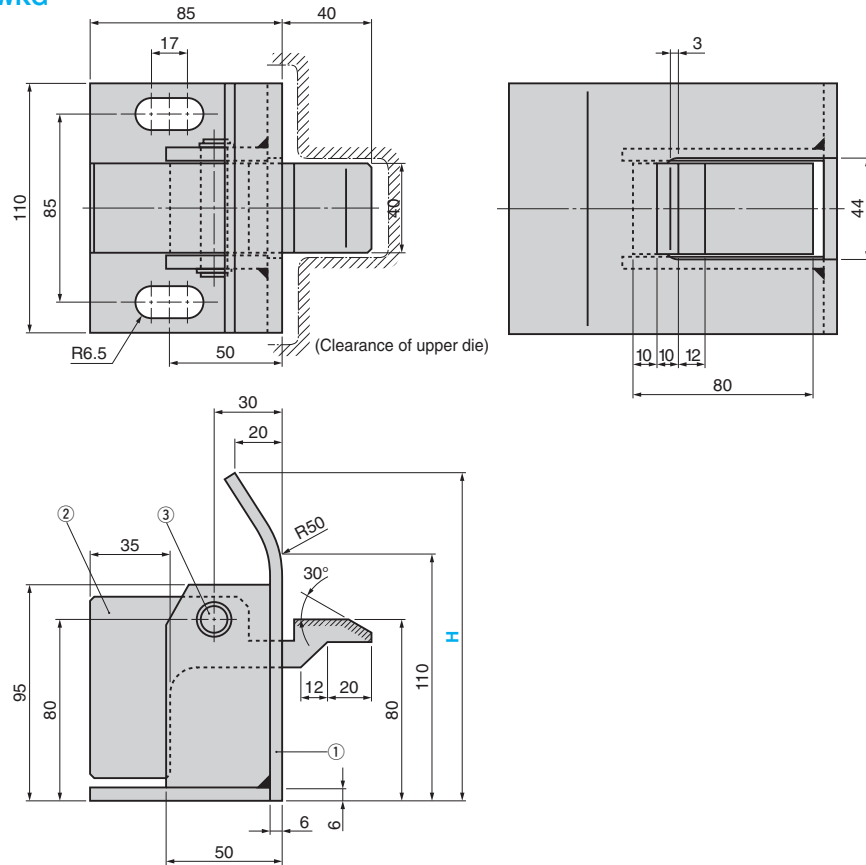

*Hatched Area Hardening HRC45 or more

Table of Components

No.	Description	Qty	Material and Remark
①	Gauge (with base)	1	SS400
②	Support Plate	1	S45C
③	Hinge Pin	1	S45C with Retaining Ring

Catalog No.	H
WKG	145



Order

Catalog No.	H
WKG	145

For Operation

- If weight of ① support plate is not sufficient for the blank weight, put some weights for use.
- To turn the support plate, load of approx. 1.2 kg is required.
- Machine the upper die to prevent interference with the gauge unit and the support plate. (The allowance for clearance is about 10 mm.)

