

SGCM

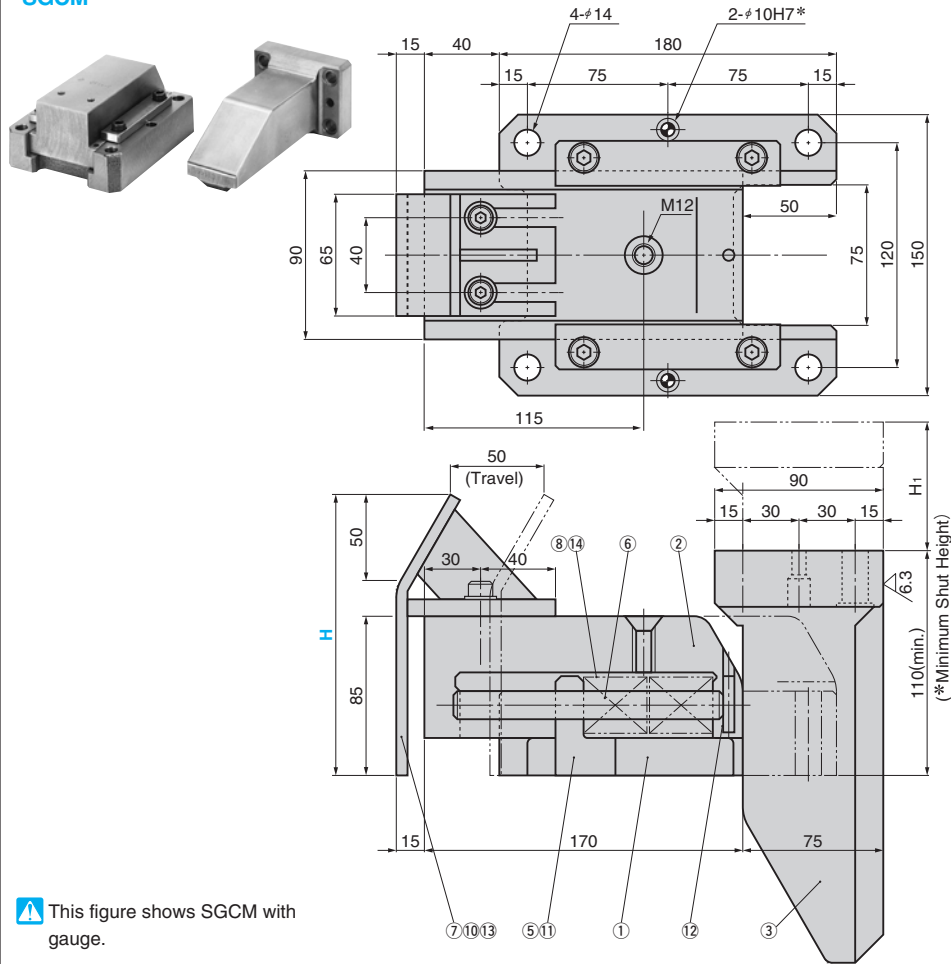

This figure shows SGCM with gauge.

Cam Diagram

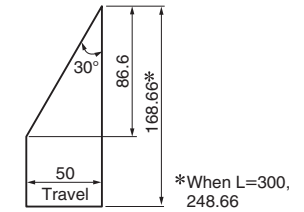

Spring Force Initial Load 141.4N(14.4kgf)
Final Load 685.3N(69.9kgf)

Table of Components

No.	Description	Qty	Material and Remark
①	Base	1	FC250
②	Slider	1	FC250 with Graphite
③	Driver	1	FC250
④	Upper Plate	2	SS400
⑤	Spring Stopper	1	SS400
⑥	Spring Guide Pin	1	SS400
⑦	Gauge Plate	1	SS400
⑧	Spring	2	SWOSC-V TF30-65
⑨	Hexagon Socket Head Bolt	4	SCM435 M10×25
⑩	Hexagon Socket Head Bolt	2	SCM435 M8×20
⑪	Set Bolt	1	SCM435 M6×10
⑫	Dowel Pin with Female Thread	1	SUJ2 φ6(m6)×30
⑬	Washer	2	For M8
⑭	Washer	1	S45C

⑧ Spring		H ₁	Catalog No.	L	H
Initial Load N	Final Load N				
141.4	685.3	168.66	SGCM	220	150
					200
		248.66		300	150
					200
				250	



Order

Catalog No.	L	H
SGCM	220	200
SGCM	220	

(With gauge)
(Without gauge)



SGCM is made to order.

* The specification was changed from φ9 dowel pin hole to φ10H7.