

SGAT

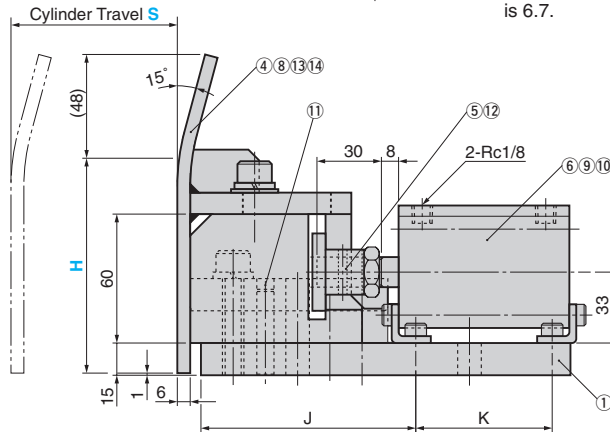
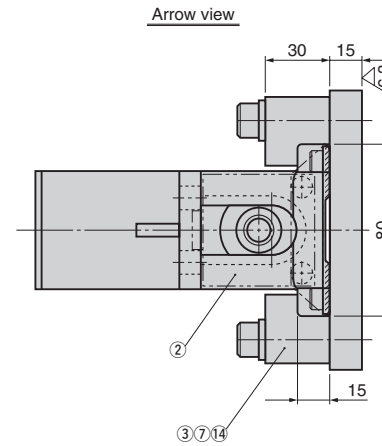
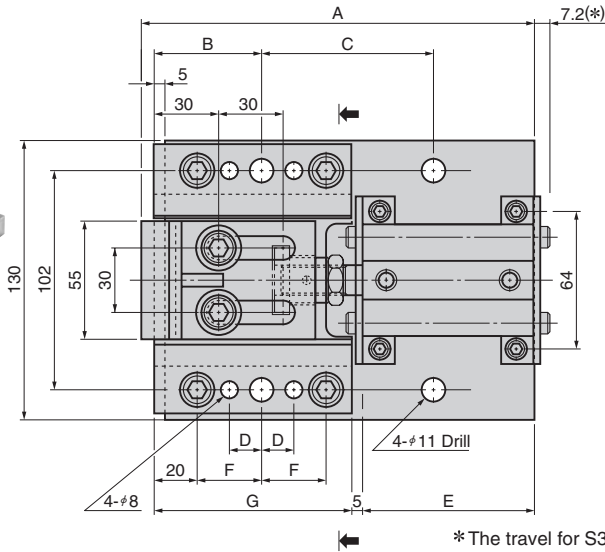
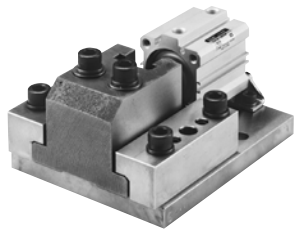

A This figure shows SGAT with gauge.

Table of Components

No.	Description	Qty	Material and Remark
①	Base Plate	1	SS400
②	Slide Holder	1	FC250 with Graphite
③	Guide Plate	2	Bronze with Graphite (SO#50 SP2)
④	Gauge Plate	1	SS400
⑤	Pusher Boss	1	S45C
⑥	Air Cylinder	1	CQ2L40 by SMC
⑦	Hexagon Socket Head Bolt	4	SCM435 M10×45
⑧	Hexagon Socket Head Bolt	2	SCM435 M10×25
⑨	Hexagon Socket Head Bolt	4	SCM435 M6×16
⑩	Spring Washer	4	S25CD For M6

No.	Description	Qty	Material and Remark
⑪	Spring Pin	4	φ8×40
⑫	Split Pin	1	SWRM10 φ4×30
⑬	Spring Washer	2	For M10
⑭	Washer	6	For M10

A	B	C	D	E	F	G	J	K	Catalog No.	Cylinder Travel S	H
163	50	60	15	60	30	92	100	43.5	SGAT	30	75 100 150
183		80		80				63.5		50	200 250 300
248	55	100	20	115	35	122	130	98.5		75	

Order

Catalog No.	S	-	H
SGAT	50	-	200
SGAT	50		

 (With gauge)
 (Without gauge)