

# DA Gauge

SWIVEL TYPE

CAD  
FILE

DART

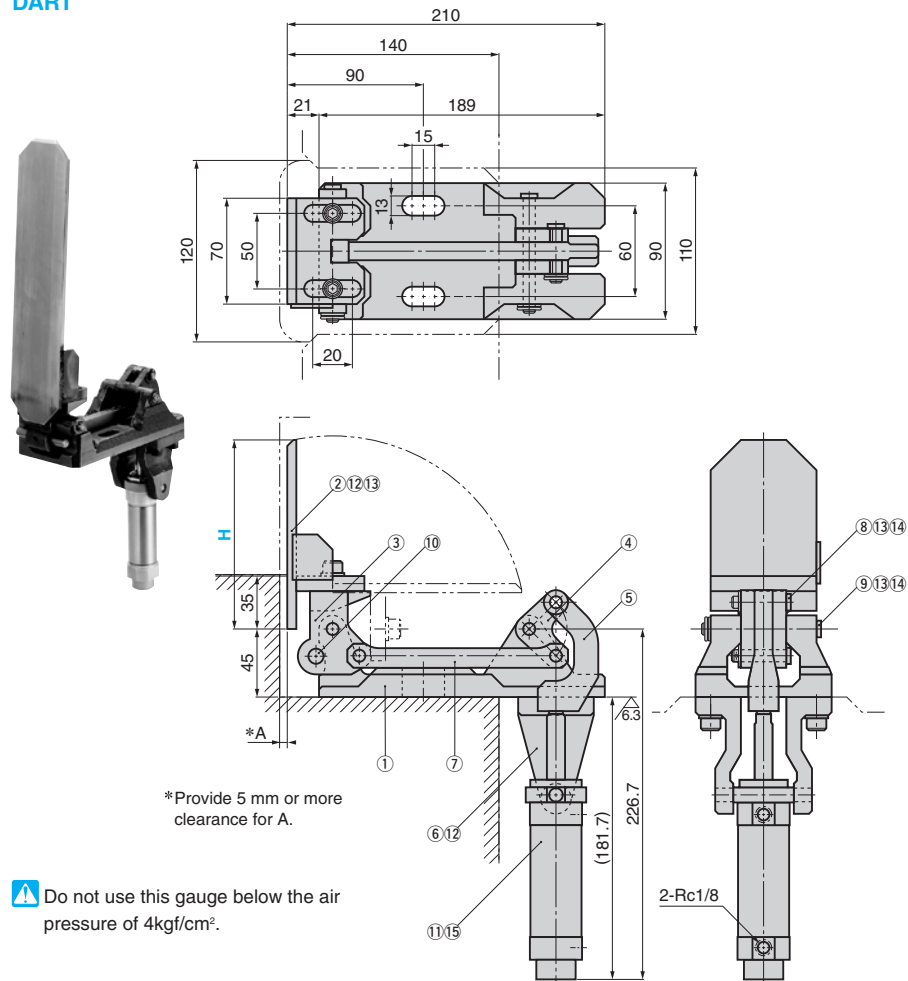

\*Provide 5 mm or more clearance for A.

⚠ Do not use this gauge below the air pressure of 4kgf/cm<sup>2</sup>.

### Table of Components

No.	Description	Qty	Material and Remark
①	Gauge Base	1	FCD550
②	Stopper Plate	1	SS400
③	Gauge Bracket	1	FCD550
④	Joint	1	FCD550
⑤	Arm	1	FCD550
⑥	Cylinder Support	2	FCD550
⑦	Rod	1	SS400
⑧	Joint Pin (S)	3	S45C
⑨	Joint Pin (L)	2	S45C

No.	Description	Qty	Material and Remark
⑩	Stopper Pin	1	SCM435
⑪	Air Cylinder	1	CM2U32-35A(SMC)
⑫	Hexagon Socket Techno-Bolt	6	SCM435 M8×25
⑬	Washer	7	For M8
⑭	Split Pin	5	#2×16
⑮	Split Pin	1	#3×30

Catalog No.	H
	75
	100
	125
DART	150
	175
	200
	225
	250



Order

Catalog No.	H
DART	150

⚠ DART is made to order.