

PKRGM

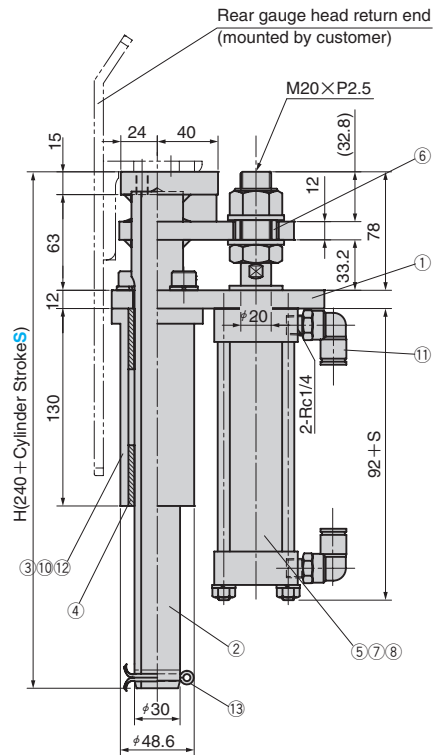
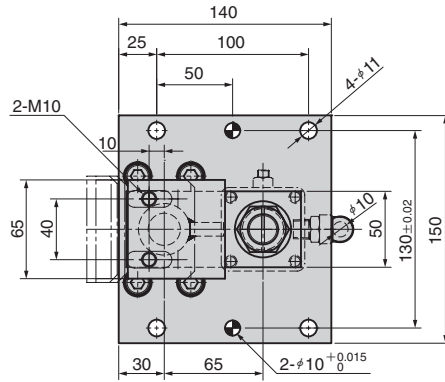

Table of Components

No.	Description	Qty	Material and Remark
①	Base Plate	1	SS400
②	Guide Post	1	STKM
③	Bushing Holder	1	SS400
④	Oilless Bushing	2	Bronze (SP2) with Graphine
⑤	Air Cylinder	1	D-MCY-RF-40 by Taiyo
⑥	Collar	1	STKM
⑦	Flat Washer	2	For M20
⑧	U Nut	1	SCM435 M20
⑩	Hexagon Socket Head Bolt	4	SCM435 M10x25
⑪	Elbow	2	10R-02ML by Chiyoda
⑫	Spring Washer	4	For M10
⑬	Cotter pin	1	φ5x40

H	Weight (kg)	Catalog No.	Cylinder Stroke S
340	6.7		100
390	7.1	PKRGM	150
440	7.4		200



Order

Catalog No.

S

PKRGM

150

For Operation

(1) When a blank sheet is placed

(2) Before stamping

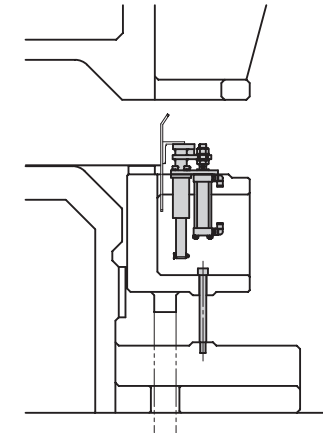
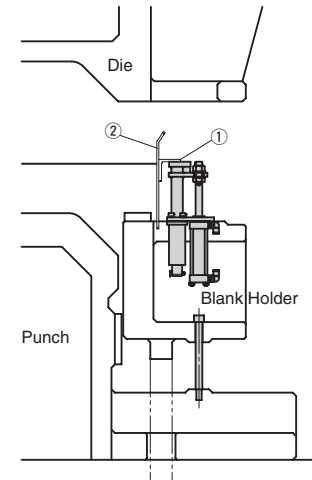

This is compatible with the mounting position of old standard part PKRG. However, the elbow mounting position was changed.