

# Outline of Punch Stripper Unit

## OUTLINE OF PUNCH STRIPPER UNIT

### Types and Features of Punch Stripper Unit

- Punch stripper unit for commercially available retainer (by Misumi).

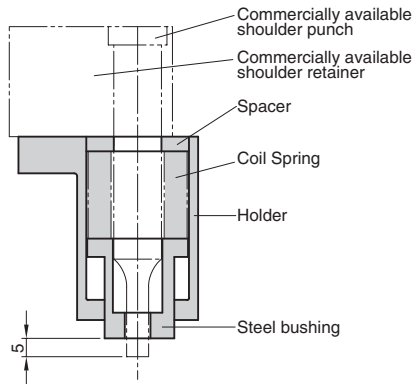

It is a punch stripper unit for commercially available retainer (by Misumi).

- It is compatible with 5 sizes of  $\phi 10, 13$  (overall length 80, 90) and  $\phi 16$  (overall length 90).
- The entry size is specified to max. 5 mm.
- The bushing end can be machined to a shape.

### Option

- Lock position of the irregular shape bushing can be changed. **-RA**

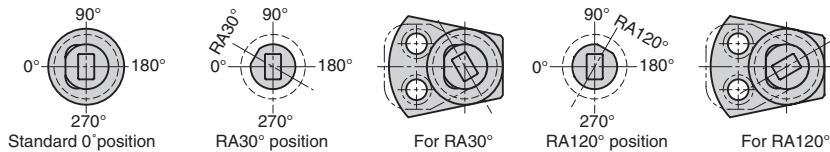

- Dowel hole is machined. (2- $\phi 6H7$ ) **-PN**

When the unit is used as the stripper for pilot punch or the lifter with pilot relief hole, dowel holes should be drilled. (Refer to the example on the following page.)

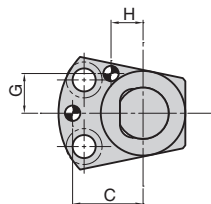

D*	C	G	H
10-13	27.5	15.5	12.5
16	32	18.5	15

\* D is punch shank diameter.

### Other examples of punch stripper unit

- It can be used as the stripper for pilot punch.

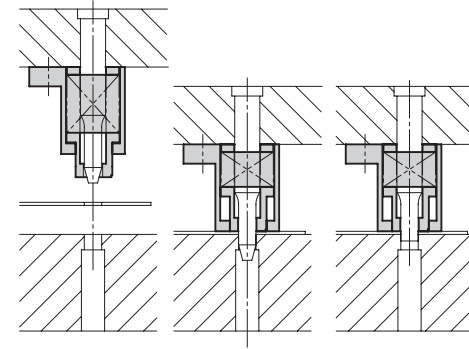

- It can be used as the lifter with pilot relief hole.

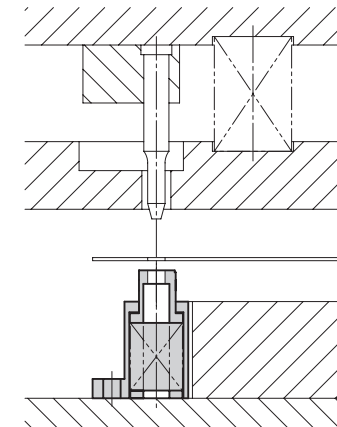

# Punch Stripper Unit

COIL SPRING TYPE

NEW CAD FILE

- BPSB** (Bushing blank type)
- BPSA** (Round hole)
- BPSR** (Square hole with radius)
- BPSE** (Oblong hole)

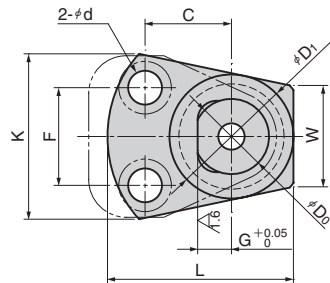
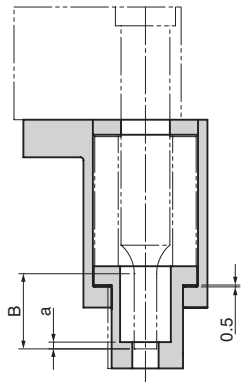
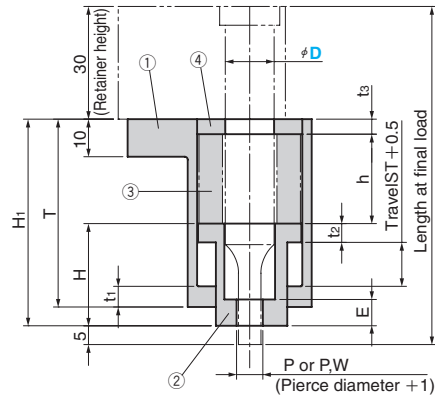

- Material :
- ① Holder (SS400, Black Oxide)
  - ② Steel bushing (S45C)
  - ③ Coil Spring
  - ④ Spacer (SS400)

## Hole of Steel Bushing

Determine the hole size with the pierce diameter + 1 mm.

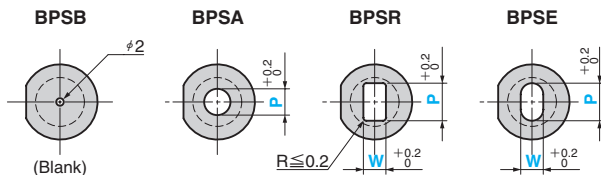

- \*Use BPSB with the pierce guide hole.
- \*Set the entry of the pierce to 5mm or less.

D	Punch Length	T	t1	H	t2	H1	E	h	t3	C	F	G	D0	D1	K	L	W	d	B	a
10	80	44	4.5	23	5.0	45	9	18	4	21	20	9	20	33	44	49.5	27	9	13	1.5
	90	50	5.5	27.2		55	8	23.8												1.3
13	80	44	4.5	23	5.0	45	9	18	4	23	26	9	20	33	44	49.5	27	9	13	1.5
	90	50	5.5	27.2		55	8	23.8												1.3
16	90	53	5.0	28	4.5	55	13	24	3	26	24	13.5	30	41	50	60.5	36	11	19	1.5

D	Punch Length	Travel ST	Initial Load	Stripper Force N(kgf) Note 1	Maximum Return Force N(kgf)	Spring Constant N/mm(kgf/mm)	Spring Used	Accessory Mounting Bolt
10	80	12	0.0	572.6( 58.1)	981.6( 99.6)	81.8( 8.3)	TL27-30	M8×60
	90	11.2		790.5( 80.6)	1427.8(145.6)	127.5(13.0)	TM27-35	
13	80	12	0.0	572.6( 58.1)	981.6( 99.6)	81.8( 8.3)	TL27-30	M8×60
	90	11.2		790.5( 80.6)	1427.8(145.6)	127.5(13.0)	TM27-35	
16	90	16	0.0	1116.5(114.4)	1624.0(166.4)	101.5(10.4)	TL35-40	M10×60

\*(Note 1): Pierce entry is set at 5 mm.

Catalog No.	D	Punch Length	Increments of 0.1 mm				
			BPSA		BPSR		BPSE
			P	P	W	P	W
<b>BPSB</b>	10	80	3.0~11.0	3.0~8.0	3.0~8.0	3.1~11.0	3.0~10.8
<b>BPSA</b>		90	3.0~11.0	3.0~8.0	3.0~8.0	3.1~11.0	3.0~10.8
<b>BPSR</b>	13	80	3.0~14.0	3.0~10.1	3.0~10.1	3.1~14.0	3.0~13.8
<b>BPSE</b>		90	3.0~14.0	3.0~10.1	3.0~10.1	3.1~14.0	3.0~13.8
	16	90	3.0~17.0	3.0~12.3	3.0~12.3	3.1~17.0	3.0~16.8



Order

Catalog No.	D	Punch Length	P	W
<b>BPSB</b>	10	80		
<b>BPSA</b>	10	80	P8.2	
<b>BPSR</b>	13	90	P8.0	W6.0



Option

Option Code	Specification
<b>RA</b>	Lock position of the irregular shape (square or oblong hole) bushing is changed (at increments of 1°).
<b>PN</b>	Dowel hole is machined. 2-φ6H7



See page 317 for option details.



Order

**BPSR13-80-P 8.0-W 6.0-RA30**  
**BPSA10-80-P 8.2-PN**

## Spring Diagram

• 10-80, 13-80

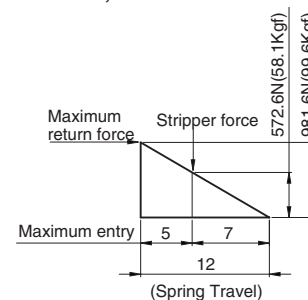

• 10-90, 13-90

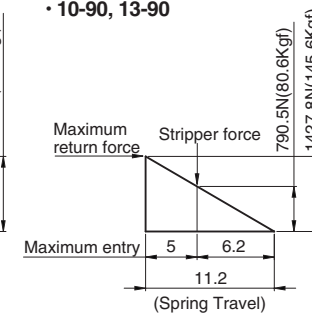

• 16-90

