

Sheet Guide Roller Set

STOCK WIDTH FIXED TYPE

CAD FILE



SGRT (Adjustable Type)

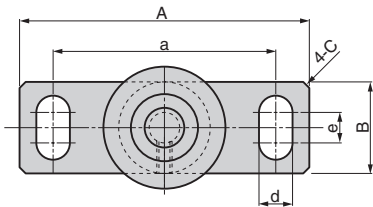

SGRR (Fixed Type)

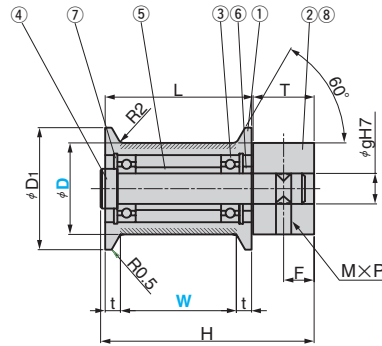
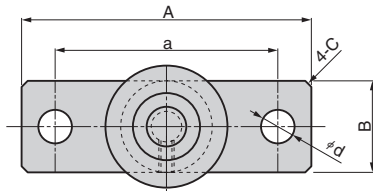

Area to be Induction Hardened (Hatched Area)

Table of Components

No.	Description	Qty	Material and Remark
①	Roller	1	S45C HRC55~
②	Base Plate	1	SS400
③	Bearing(Ball bearing)	2	Refer to the standard table below.
④	Roller Set Pin	1	S45C
⑤	Spacer for Bearing	1	STB
⑥	Spacer for Bearing	1	STB
⑦	C-shaped Snap Ring	2	Spring Steel
⑧	Hexagon Socket Set Screw	1	SCM435

D	W	A	a	B	C	d	e	D ₁	H	L	t	T	F	g	M×P
30	38	95	73	30	2	11	10	40	70	48	5	20	10	10	M5×P0.8
55	70	145	115	55	5	13	20	75	127	86	8	35	20	20	M8×P1.25

③ Bearing	Catalog No.	D	W
B6900ZZ	SGRT	30	38
B6004ZZ	SGRR	55	70

Order
 SGRT 55 - 70

Sheet Guide Plate

FLEXIBLE TYPE

NEW CAD FILE

SGNHR
SGNHL

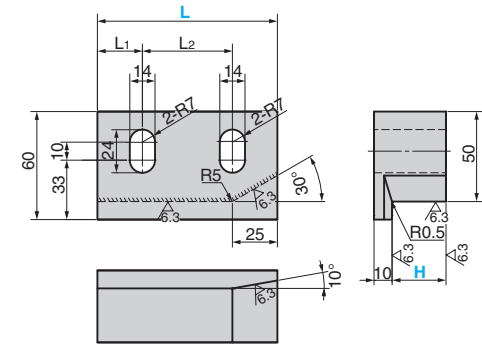

* This illustration shows R type SGNHR.

SGSHR
SGSHL

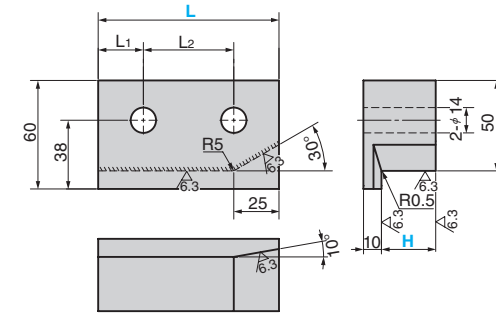

* This illustration shows R type SGSHR.

Material : S45C
 Hardness : HRC55 ~
 Area to be Induction Hardened (Hatched Area)

L	L ₁	L ₂
100	25	50
150	35	80

Catalog No.	H	L
	30	100
	40	100
	40	150
SGNHR	50	100
SGNHL	50	150
SGSHR	60	100
SGSHL	60	150
	70	100
	70	150
	80	100
	80	150

Order -
 SGNHR 50 - 150
 SGSHL 40 - 100