

# Spring Unit for Cam Return

STANDARD FINAL PRESSURE TYPE

CAD FILE

TOKSL 30

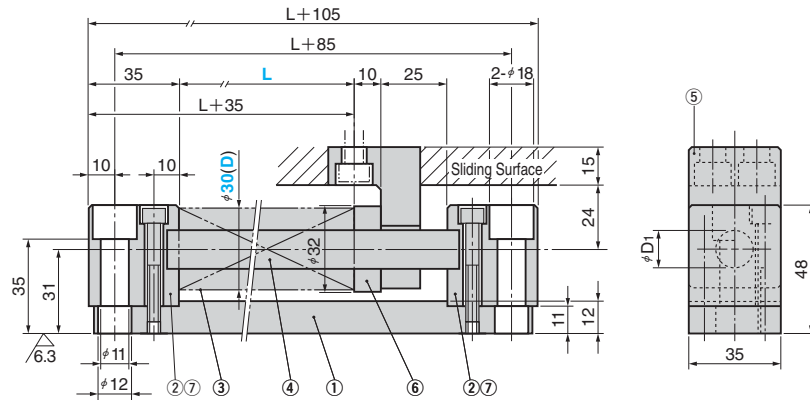
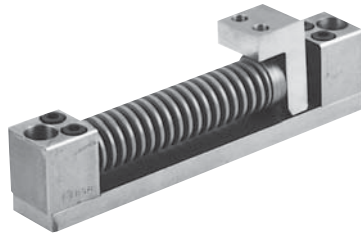

TOKSF 40  
TOKSL 40

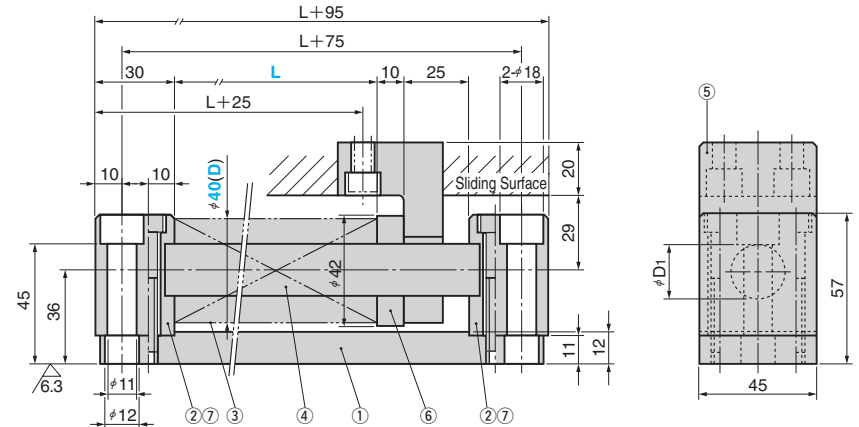

⑤ Return Plate TRP

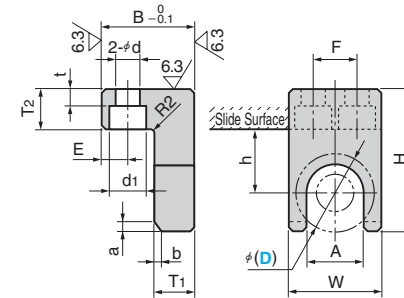

•Chamfer Dimension

D	a	b
30	4	3
40	5	3

Table of Components

No.	Description	Qty	Material and Remark
①	Base Plate	1	SS400
②	Spring Block	2	SS400
③	Spring	1	SWOSC-V(TF and TL)
④	Spring Guide Pin	1	S45C

No.	Description	Qty	Material and Remark
⑤	Return Plate	1	SS400
⑥	Washer	1	FC250
⑦	Hexagon Socket Head Bolt	4	SCM435

Spring	Standard Value (one million strokes)		Maximum Value (300,000 strokes)		Spring Constant N/mm	D <sub>1</sub>	Catalog No.	(D)	L
	Travel	Load N	Travel	Load N					
TL30-100	32		40		29.69	14	TOKSL	30	100
TL30-125	40	951	50	1187	23.76				125
TL30-150	48		60		19.80				150
TL30-175	56		70		16.97				175
TF40-90	36		45		27.85	20	TOKSF	40	90
TF40-125	50	62.5	20.05	125					
TF40-150	60	75	16.71	150					
TL40-125	40	50	42.29	125					
TL40-150	48	60	35.24	19	TOKSL	40	150		
TL40-175	56	70	30.21				175		
TL40-200	64	80	26.43				200		
TL40-250	80	100	21.14				250		



Order

Catalog No.	(D)	L
TOKSL	30	125
TOKSF	40	125



Both TOKSF and TOKSL are made to order.

Return Plate

Application	W	B	H	A	h	T <sub>1</sub>	T <sub>2</sub>	F	E	d	d <sub>1</sub>	t	Catalog No.	(D)
TOKSL30	35	35	53	21	24	15	15	18	10	9	14	5	TRP	30
TOKSF40	45	40	69	25	29	15	20	25	10	9	14	10		40
TOKSL40														40



Order

Catalog No.	(D)
TRP	30



TRP is made to order.

# Spring Unit for Cam Return

STANDARD FINAL PRESSURE TYPE

CAD  
FILE

TOKSF 60  
TOKSL 60

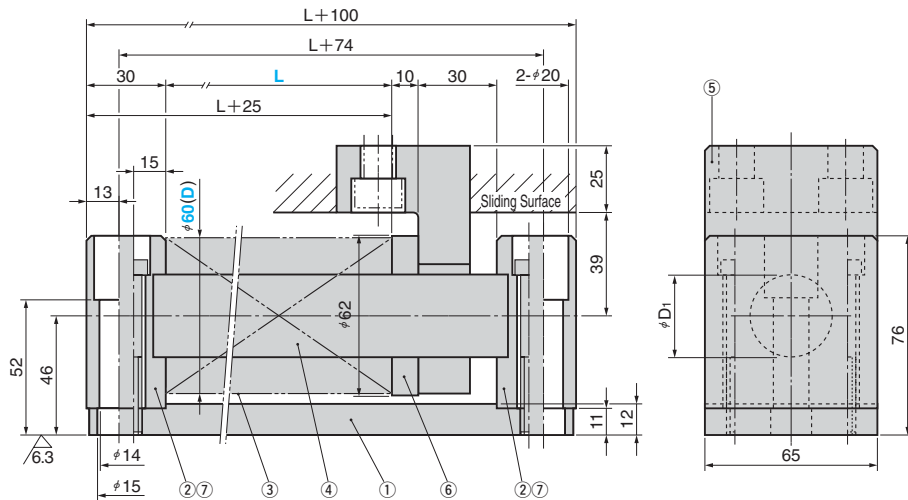
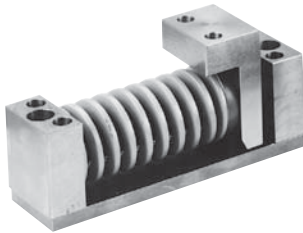

## ⑤ Return Plate TRP

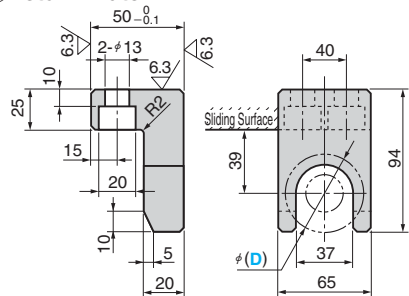

## Table of Components

No.	Description	Qty	Material and Remark
①	Base Plate	1	SS400
②	Spring Block	2	SS400
③	Spring	1	SWOSC-V(TF and TL)
④	Spring Guide Pin	1	S45C

No.	Description	Qty	Material and Remark
⑤	Return Plate	1	SS400
⑥	Washer	1	FC250
⑦	Hexagon Socket Head Bolt	4	SCM435

Spring	Standard Value (one million strokes)		Maximum Value (300,000 strokes)		Spring Constant N/mm	D <sub>1</sub>	Catalog No.	(D)	L
	Travel	Load N	Travel	Load N					
TF60-125	50		62.5		45.16				125
TF60-150	60		75		37.63				150
TF60-175	70	2260	87.5	2820	32.25	31.8	TOKSF	60	175
TF60-200	80		100		28.22				200
TF60-250	100		125		22.58				250
TF60-300	120		150		18.81				300
TL60-125	40		50		95.33				125
TL60-150	48		60		79.44				150
TL60-175	56	3810	70	4770	68.10	28.6	TOKSL	60	175
TL60-200	64		80		59.58				200
TL60-250	80		100		47.67				250
TL60-300	96		120		39.72				300



Order

Catalog No.  
TOKSF

(D)  
60

- L  
200



Both TOKSF and TOKSL are made to order.

## Return Plate

Application	Catalog No.	(D)
TOKSF60	TRP	60
TOKSL60		



Order

Catalog No.  
TRP

(D)  
60



TRP is made to order.