

CBSL

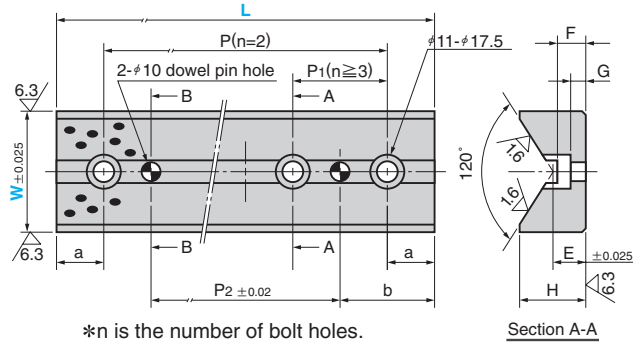

● Sliding Direction
↔

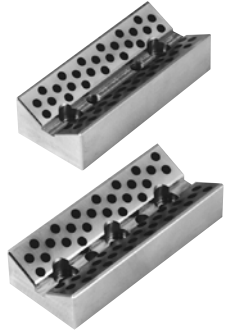
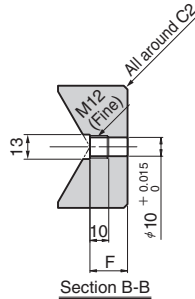

Material : Bronze with Graphite (SO#50 SP2)

CBSPL

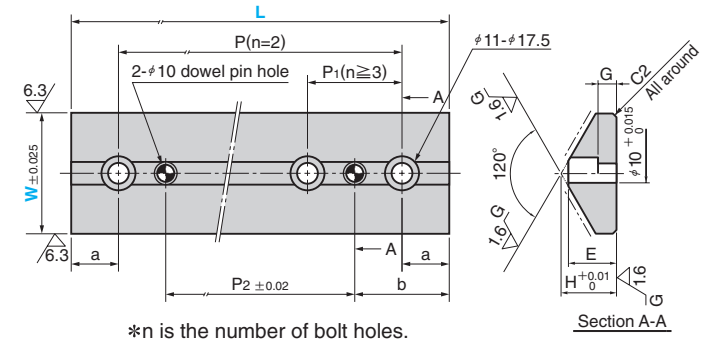

• Combined dimensions of CBSL and CBSPL
h=50

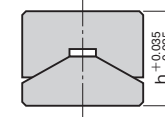

*----- area
Area to be Induction Hardened
Material : S45C Hardness : HRC55 or more

H	a	b	P	P ₁	No. of Bolt Holes n	P ₂	E	F	G	Catalog No.	W	L
37	20	40	60	—	2	20	20	20	10	CBSL	65	100
			75			25						125
	100	50	150									
	—	75	100	100	200							
			100	150	250							
			125	200	300							

Order -

H	a	b	P	P ₁	No. of Bolt Holes n	P ₂	E	G	Catalog No.	W	L
30	20	40	60	—	2	20	26	10	CBSPL	65	100
			75			25					125
	100	50	150								
	—	75	100	100	200						
			100	150	250						
			125	200	300						

Order -