

# Cam Slide Plate

STEEL TYPE

CAD FILE

## SHCPA (Steel Lower Type)

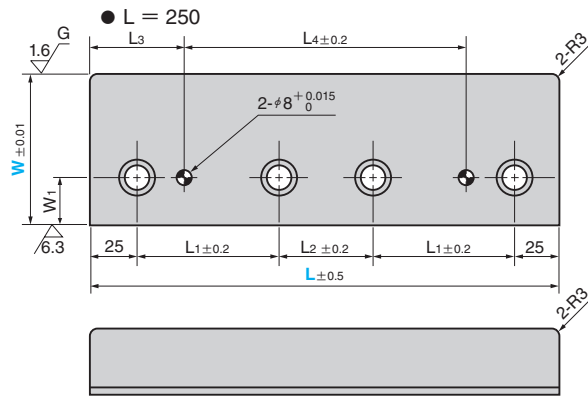
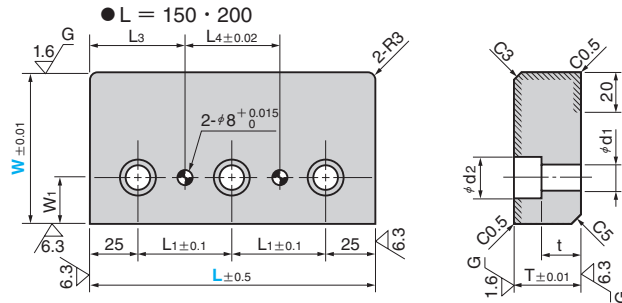

## SHCP (Steel Side Type)

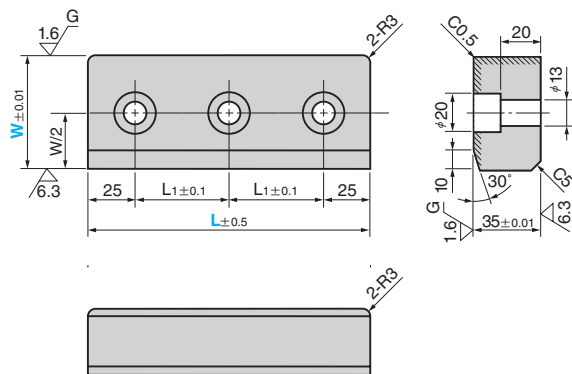

SHCPA and SHCP  
Material : S45C  
HRC55 or more  
Area to be Induction Hardened  
(Hatched Area)

T	L1	L2	L3	L4	W1	t	d1	d2	Catalog No.	W	L
20	50	-		60							150
	75	50	45	110	20	8	11	18		55	200
35	50	-		50							150
	75	50	50	100	25	21	13	20	SHCPA	80	200
50	50	-		40							150
	75	50	55	90	35	32	18	26		95	200
				140							250

L1	Catalog No.	W	L
50			150
75		60	200
100			250
50	SHCP		150
75		80	200
100			250



Order

Catalog No.	W	-	L
SHCPA	55	-	150
SHCP	60	-	150

● When cam side block (MCSRW and MCSRW, P.225) is used together with wear plate (See figure in the right.)

Cam Slide Plate SHCPA Thickness	MCSRW Thickness T	Wear Plate Thickness
20	30	10
35	45	
50	60	
20	40	20
35	55	
50	70	



L size 250 of SHCPA and SHCP is made to order.



Example

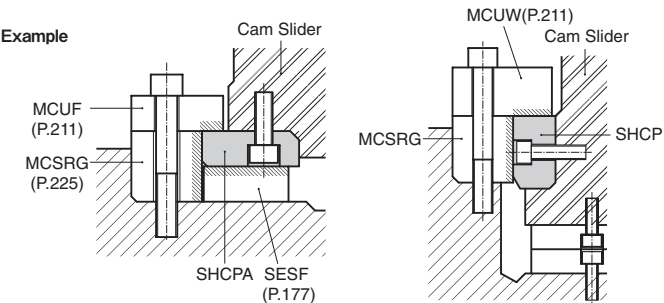

■ We are ready to accept requests or orders for special parts.