

Cam Side Plate

FOR CAM SLIDER

NEW

CAD FILE

SOUW (Bronze with Graphite Type)
 SOUG (FC with Graphite Type)

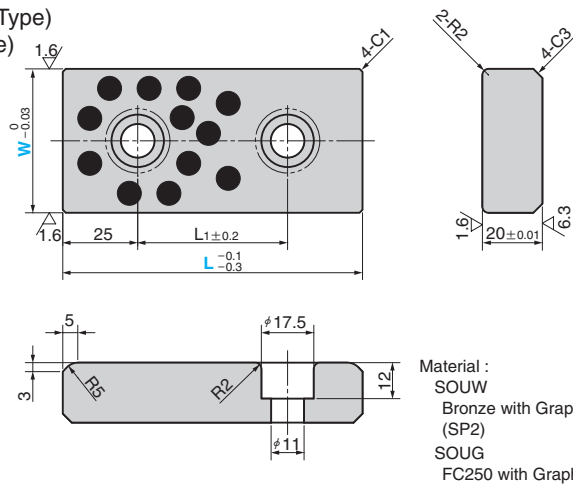

● Sliding Direction

W(Actual Dimensions)	L ₁	Catalog No.	W(Nominal)	L
27.5	50		28	100
	75			125
	100			150
37.5	50	SOUW SOUG	38	100
	75			125
	100			150
47.5	50		48	100
	75			125
	100			150

Order -
 SOUW 38 - 100

Cam Gib Plate

FOR CAM SIDE PLATE

NEW

CAD FILE

SLK

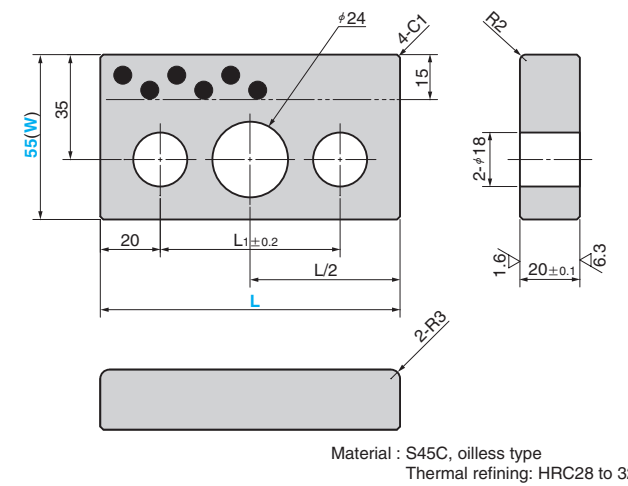

● Sliding Direction

L ₁	Catalog No.	(W)	L
60			100
85	SLK	55	125
110			150

Order -
 SLK 55 - 100

EX Example

