

MCUX

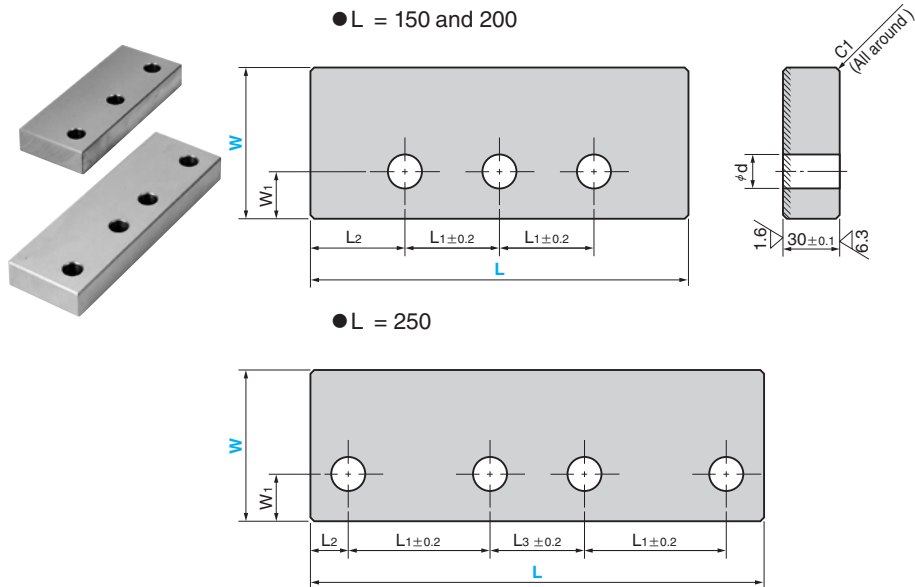

Material : Copper Powder Sintered(#220)  
 Hatched Area Sintered  
 Thickness 1.2 mm or more  
 SS400(base plate)

L <sub>1</sub>	L <sub>2</sub>	L <sub>3</sub>	W <sub>1</sub>	d	Catalog No.	W	L
50							150
75	25		25	18	MCUX	82	200
		50					250

Order   -   
 MCUX 82 - 200

EX

Example

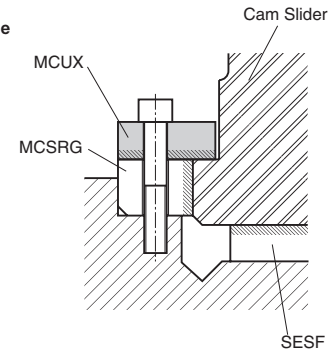

● Use MCSR50 if you use combined with MCSR50 and MCSRW(P.225).