

TWXT (2-hole Type)

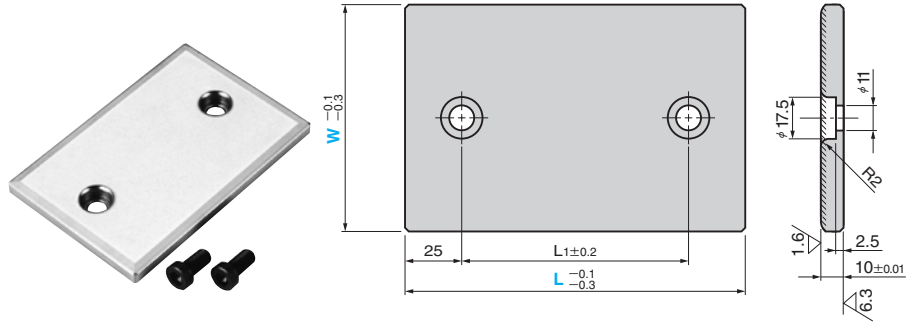

Please refer page 183 about the chamfer.

● Sliding Direction



● Special brazier head bolt (LCS standard)
LCS10-20

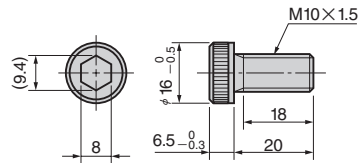

Material : Copper powder sintered (SO#200)
Hatched Area Sintered
Thickness 1.2 mm or more
SS400(base plate)
Accessory : Mounting Bolt

L1	Catalog No.	W	L
50			100
75			125
100		100	150
150			200
200			250
75	TWXT		125
100		125	150
150			200
200			250
100		150	150
150			200
200			250



Order

Catalog No.	W	L
TWXT	125	125