

# Pad Guide Block

CORNER GUIDE TYPE

CAD FILE

# Pad Guide Pin Set

FOR PAD GUIDE

Addition

CAD FILE

PGBB (Dowel Pin Prepared Hole Type)

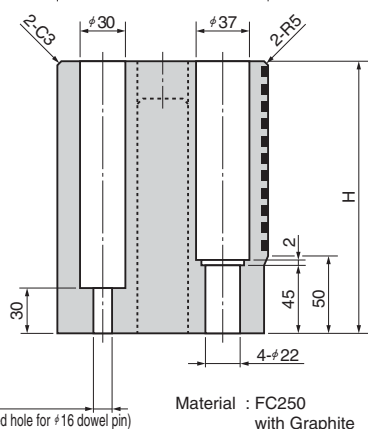
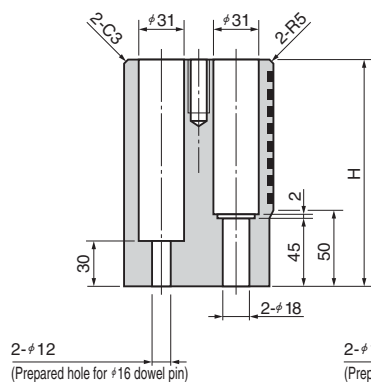
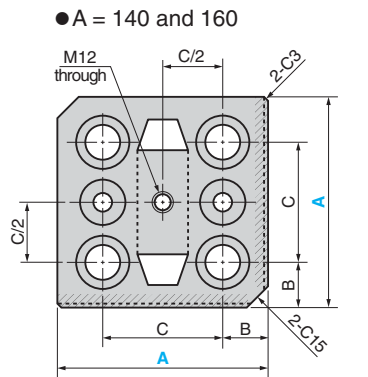
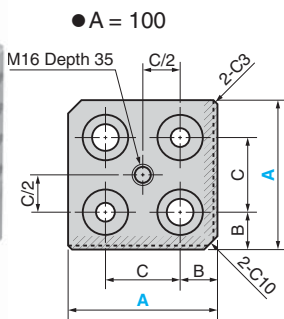

Material : FC250 with Graphite (Hatched Area)

B	C	H	Catalog No.	A
25	50	150		100
30	80	180	PGBB	140
30	100	200		160

Order



Example

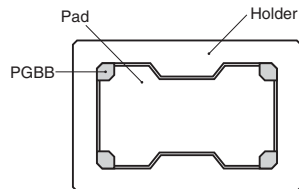

SKP

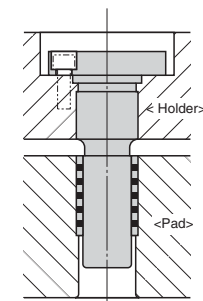
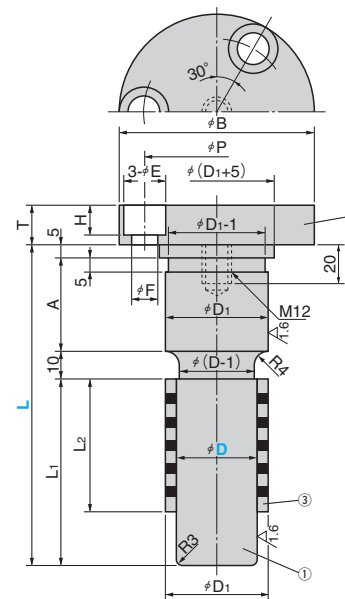

D1	Tolerance
38	0
62	-0.03
96	0
	-0.04

Material :  
 ① S45C HRC55~  
 ② SS400  
 ③ FC250 with Graphite

① Guide Pin		③ Bushing		② Set Plate							Catalog No.	D	L			
D Tolerance	L1	A	D1	I.D. (D)	O.D. (D1)	L2	B	T	P	E				F	H	
30	-0.10 -0.15	50	35	38	30	38	50	80		59				SKP	50	100
		70							15		18	12	11			135
50		100	50	62	50	62	70	105		83				SKP	50	165
		150														215
80	-0.10 -0.20	100	80	96	80	96	100	145	18	120	20	14	13	SKP	80	195
		150														245



Order

Catalog No.  D  - L



Example

This is the guide post type pad guide. The wear plates can be eliminated by using this item. Oilless type bushing is used.



Option

Option Code	Specification
BUL	Shipment without bushing



Order SKP30-120-BUL