

Guide Post Set

MOVABLE STOPPER AND ALUMINUM BALL SLIDER TYPE

CAD FILE

For selection criteria of the guide post length (effective movable range of ball slider), refer to pages from 119.



SGA
SGAL (Type for Dimension L)

With dowel pin hole
SGAN
SGANL (Type for Dimension L)

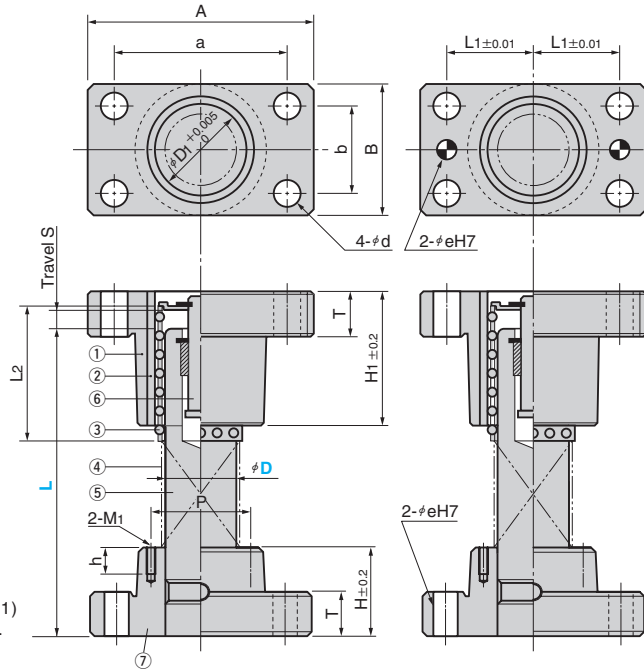

Tapped holes (2-M1) on Dia. φ38 and over.

Table of Components

No.	Description	Qty	Material and Remark	Catalog No.
①	Guide Bushing	1	FC250	
②	Inner Bushing	1	SUJ2 Induction hardening HRC58 or more	BGB BGBN
③	Ball Slider	1	A5052S	BSA
④	Spring	1	SWP2	RSS
⑤	Guide Post	1	SUJ2 Induction hardening HRC58 or more	BGPM
⑥	Movable Stopper	1	SCM415 (support plate SPCC)	
⑦	Guide Holder	1	FC250	GPH GPHN
Accessories	Hexagon Socket Head Bolt	8	SCM435	
	Dowel Pin with Female Thread	4	SUJ2 Tolerance m6	

Accessories

D	Hexagon Socket Head Bolt	Dowel Pin
25	M 8×35	φ 8×30
32	M10×40	
38	M10×45	φ10×40
50	M12×50	

D Tolerance	D ₁	A	a	B	b	T	H	P	M ₁	h	H ₁	d	L ₂	Travel S max	L ₁	e	H7
25	+0.024 +0.015	31	84	66	48	30	20	30	-	-	50	9	50	20	33	8	
32		40	100	76	58	36		40			60	11	60	25	38		+0.015 0
38	+0.028 +0.017	48	130	100	75	44	25	50	60	M5	15	70	70	30	50	10	
50		60	155	125	90	60		65	72	M6		90	90	40	62.5		

Catalog No.	D	L
	25	90 100 110 120 130 140 150 160 170 180 200
SGA SGAN	32	110 120 130 140 150 160 170 180 200 220 240 260
	38	130 140 150 160 170 180 200 220 240 260 300
	50	170 180 200 220 240 260 300 350

Catalog No.	D	L Increments of 1 mm
	25	90~200
SGAL	32	110~260
SGANL	38	130~300
	50	170~350

Order

Catalog No.	D	-	L
SGA	38	-	200
SGAL	32	-	155

Option See page 116~ for option details.

Option Code	Specification
C	Dowel pin hole for location is drilled at the center of the guide post.
M	Tapped hole for the height block is drilled on the guide holder. (D=25, 32 only)
RH	Guide holder is changed to the inverted mounting type.
RB	Guide bushing is changed to the inverted mounting type.
RHB	Both guide bushing and holder are changed to the inverted mounting type.
HK	Guide holder height is machined to the tolerance of ±0.1.
BK	Guide bushing height is machined to the tolerance of ±0.1.
HBK	Both guide holder and bushing heights are machined to the tolerance of ±0.1.
BM	Tapped hole for lifting bolt is drilled on the guide bushing.
HM	Tapped hole for jack screw is drilled on the guide holder.

Order SGAL 25 - 155 - HK - BM