

SOBF

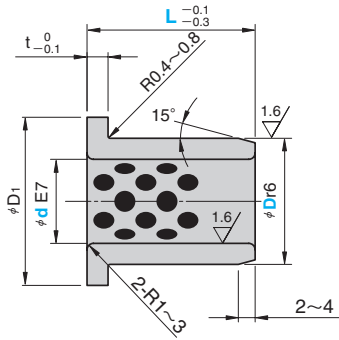

● Sliding Direction



- Mating post tolerance
General use (high load) d8
General use (light load) e7
High precision f7
- Recommended hole machining tolerance H7

Material : Bronze with Graphite (SO#50 SP2)



Order

Catalog No. **SOBF** d **35** - D **45** - L **25**

d E7	D r6	D1	t	L	Catalog No.	d	D	L
8	12	20		10	SOBF	8	12	10
				15		8	12	15
				10				
			2	12		10	14	12
				15		10	14	15
				17				17
				20				20
				15				15
				20				20
				25				25
				30				30
				15				15
				20			20	
				25			25	
				15			15	
				20			20	
				25			25	
				15			15	
				20			20	
				23			23	
				25			25	
				30			30	
				35			35	
				40			40	
				20			20	
				30			30	
				15			15	
				20			20	
				25			25	
				30			30	
				35			35	
				40			40	
				20			20	
				25			25	
				30			30	
				35			35	
				40			40	
				15			15	
				20			20	
				25			25	
				30			30	
				35			35	
				40			40	

d E7	D r6	D1	t	L	Catalog No.	d	D	L	
				15	SOBF			15	
				20					20
				25					25
				30					30
				35					35
				40					40
				50					50
				20					20
				25					25
				30					30
				35					35
				40					40
				50				50	
				20				20	
				25				25	
				30				30	
				35				35	
				40				40	
				50				50	
				20				20	
				25				25	
				30				30	
				35				35	
				40				40	
				50				50	
				20				20	
				25				25	
				30				30	
				35				35	
				40				40	
				50				50	
				20				20	
				25				25	
				30				30	
				35				35	
				40				40	
				50				50	
				20				20	
				25				25	
				30				30	
				35				35	
				40				40	
				50				50	
				20				20	
				25				25	
				30				30	
				35				35	
				40				40	
				50				50	
				20				20	
				25				25	
				30				30	
				35				35	
				40				40	
				50				50	
				20				20	
				25				25	
				30				30	
				35				35	
				40				40	
				50				50	
				20				20	
				25				25	
				30				30	
				35				35	
				40				40	
				50				50	
				20				20	
				25				25	
				30				30	
				35				35	
				40				40	
				50				50	
				20				20	
				25				25	
				30				30	
				35				35	
				40				40	
				50				50	
				20				20	
				25				25	
				30				30	
				35				35	
				40				40	
				50				50	
				20				20	
				25				25	
				30				30	
				35				35	
				40				40	
				50				50	
				20				20	
				25				25	
				30				30	
				35				35	
				40				40	
				50				50	
				20				20	
				25				25	
				30				30	
				35				35	
				40				40	
				50				50	
				20				20	
				25				25	
				30				30	
				35				35	
				40				40	
				50				50	
				20				20	
				25				25	
				30				30	
				35				35	
				40				40	
				50				50	
				20				20	
				25				25	
				30				30	
				35				35	
				40				40	
				50				50	
				20				20	
				25				25	
				30				30	
				35				35	
				40				40	
				50				50	
				20				20	
				25				25	
				30				30	
				35				35	
				40				40	
				50				50	
				20				20	
				25				25	
				30				30	
				35				35	
				40				40	
				50				50	
				20				20	
				25				25	
				30				30	
				35				35	
				40				40	
				50				50	
				20				20	
				25				25	
				30				30	
				35				35	
				40				40	
				50				50	
				20				20	
				25				25	
				30				30	
				35				35	
				40				40	
				50				50	
				20				20	
				25				25	
				30				30	
				35				35	
				40				40	
				50				50	
				20				20	
				25				25	
				30				30	
				35				35	
				40				40	
				50				50	
				20				20	
				25				25	
				30				30	
				35				35	
				40				40	
				50				50	
				20				20	
				25				25	
				30				30	
				35				35	
				40				40	
				50				50	
				20				20	
				25				25	
				30				30	
				35				35	
				40				40	
				50				50	
				20				20	
				25				25	
				30				30	
				35				35	
				40				40	
				50				50	
				20				20	
				25				25	
				30				30	
				35				35	
				40				40	
				50				50	
				20				20	
				25				25	
				30				30	
				35					