

# Guide Post

GUIDE POST

NEW CAD FILE

GPTB

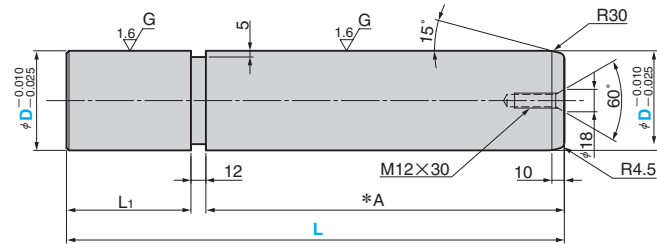

\*Induction hardening at A

Material : S45C  
Hardness : HRC55 to 60  
(Induction hardening at A)

L1	Catalog No.	D	L
100	GPTB	80	350
		100	400
120	GPTB	100	350
		120	400
150		120	450

Order 

Catalog No.	D	-	L
GPTB	80	-	350

# Guide Post · Loosening Lock Washer

WASHER FOR GUIDE POST

NEW

GPTS

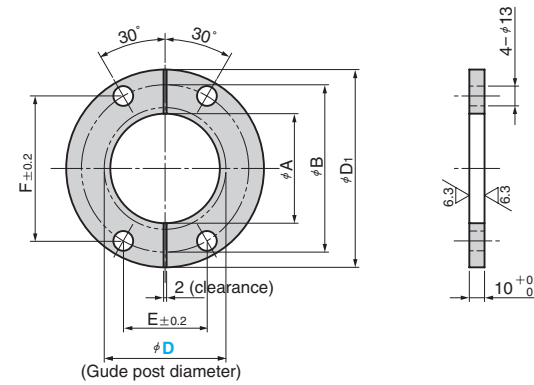

Material : STKM13A

A	B	D <sub>1</sub>	E	F	Catalog No.	D
72	110	130	55	95.3	GPTS	80
92	130	150	65	112.6		100
112	156	177.8	78	135.1		120

Order 

Catalog No.	D
GPTS	80