

# Lifting Hooks

REGULAR TYPE

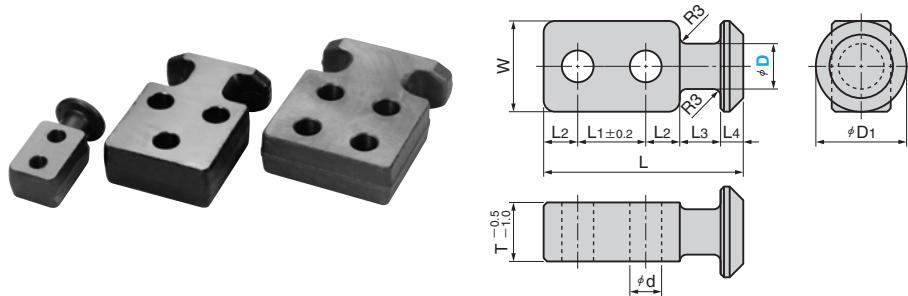

HKP10 to 40



HKP50

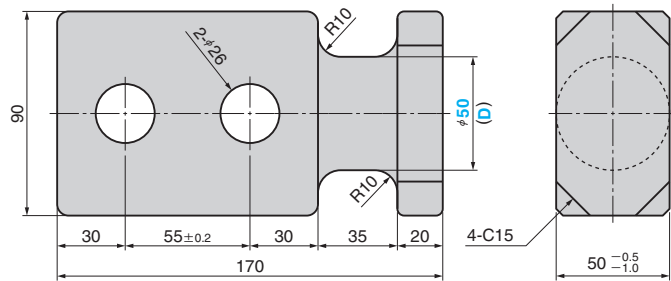

▲ After tightening mounting bolts, weld the circumference of the hook to the die.

HKP63

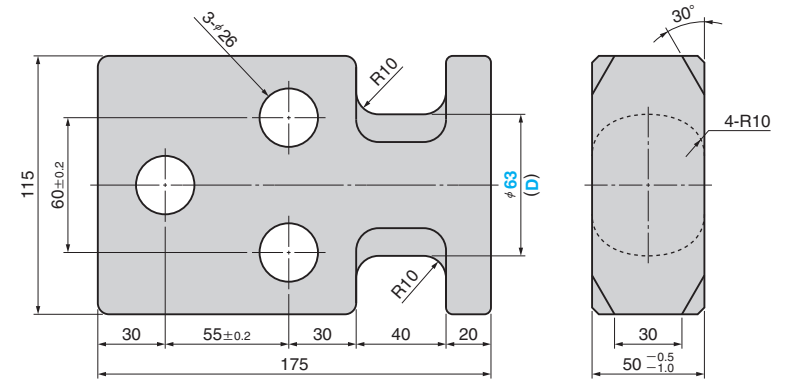

HKP80

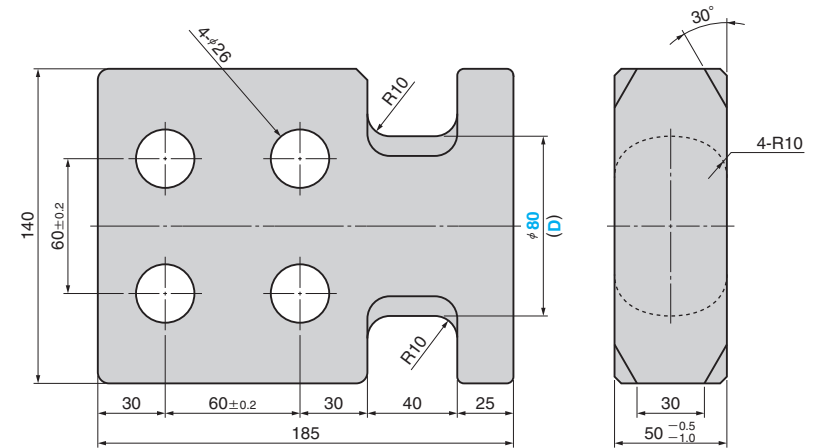

Material : SS400

W	L	T	L1	L2	L3	L4	d	D1	Allowable Load N (kgf)/1P	Catalog No.	D
28	50	18	16	8	10	8	7	28	1569 ( 160)		10
32	56	20	18	10			9	32	3530 ( 360)		12
36	67	24	22	12	13	14	11	36	4511 ( 460)	HKP	16
40	88	26	30	15	18		10	40	5492 ( 560)		20
48	92	35	30	20	12	14	20	48	6570 ( 670)		25
55	118	40					40	20	25		13
70	138	50	45	24	30	15	22	70	19123 (1950)		40

Allowable Load N (kgf)/1P	Catalog No.	(D)
27459 (2800)		50
39227 (4000)	HKP	63
50995 (5200)		80

Order   - Option  
 HKP 40  
 HKP 63 - BT

■ Option -BT

Including following Hexagon Socket Head Bolt.

(D)	Mounting bolt	(D)	Mounting bolt
10	M 6 × 30	32	M16 × 70
12	M 8 × 35	40	M20 × 90
16	M10 × 45	50	M24 × 90
20	M12 × 50	63	M24 × 90
25	M12 × 60	80	M24 × 100

Die Setting Components