

Lifting Hooks

LUG TYPE

CAD
FILE

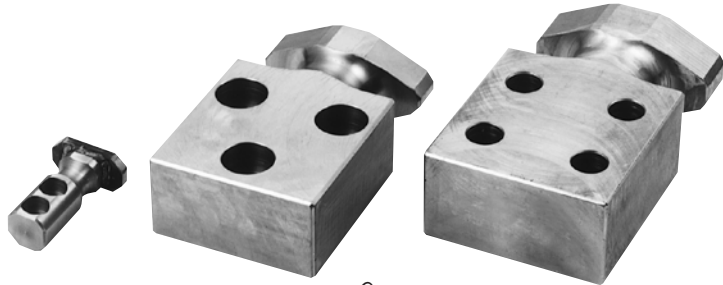

THH25 to 50

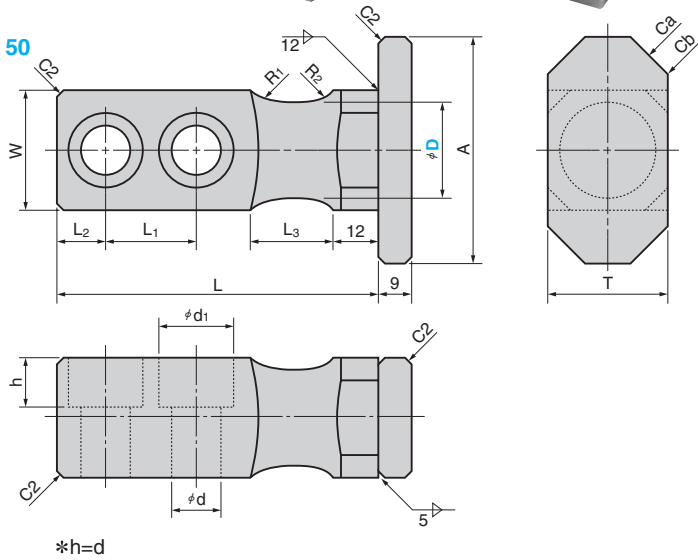

⚠ After tightening mounting bolts, weld the circumference of the hook to the die.

Material : SS400

THH60

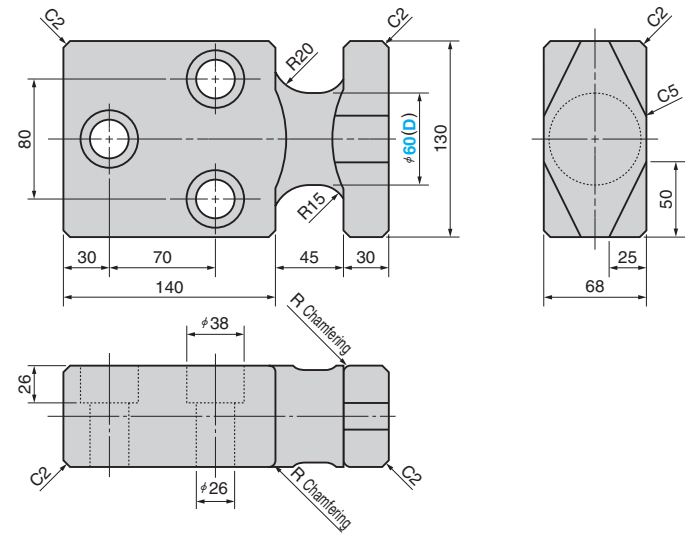

THH70

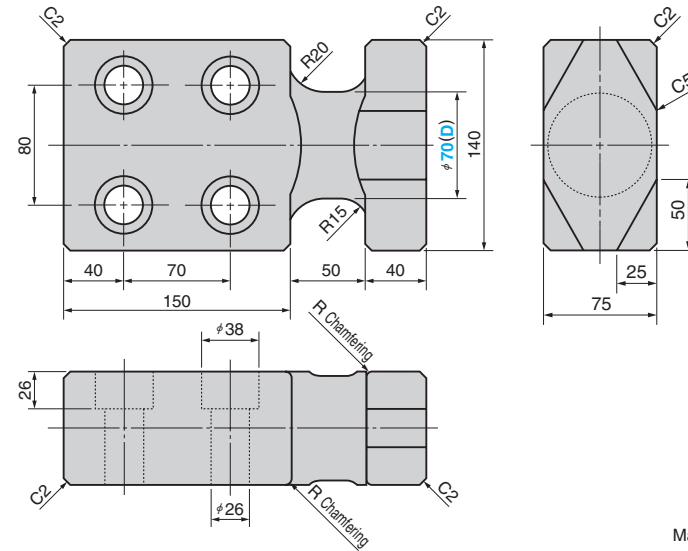

Material : SS400

A	L	L ₁	L ₂	L ₃	W	R ₁	R ₂	d	d ₁	T	Ca	Cb	Allowable Load kgf/1P	Catalog No.	D
60	85	24	13	22	32	15	10	13	20	32			800		25
80	120	44	16	32	40	20	12	18	26	40	10	2	1500	THH	32
90	140	52	18	40	50	20	12	22	32	50			2400		40
120	160	59	22	45	60	20	12	26	38	60	20	5	3500		50

Allowable Load kgf/1P	Catalog No.	(D)
6000	THH	60
8000		70



Order

Catalog No. THH (D) 60

Die Setting
Components